

# Operating Instructions Maintenance Guide 1 Copier System Edition

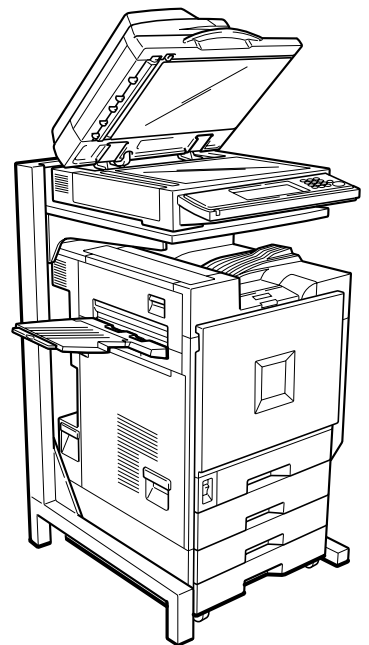

For safety, please read this manual carefully before you use this product and keep it handy for future reference.

## **Introduction**

This manual contains detailed instructions on the operation and maintenance of this machine. To get maximum versatility from this machine all operators should carefully read and follow the instructions in this manual. Please keep this manual in a handy place near the machine.

Please read "Safety Information" in this manual before using this machine. It contains important information related to USER SAFETY and PREVENTING EQUIPMENT PROBLEMS.

## **Power Source**

120 V, 60 Hz, 12 A or more (10A: Printer, 2A: Copier System)

Please be sure to connect the power cable to a power source as above.

## **Operator Safety:**

This machine is considered a CDRH class I laser device, safe for office/ EDP use. The machine contains 7 milliwatt, 645 - 660 nanometer wavelength, AlGaInp Laser Diode. Direct (or indirect reflected) eye contact with the laser beam might cause serious eye damage. Safety precautions and interlock mechanisms have been designed to prevent any possible laser beam exposure to the operator.

## **Laser Safety:**

The Center for Devices and Radiological Health (CDRH) prohibits the repair of laser-based optical unit in the field. The optical housing unit can only be repaired in a factory or at a location with the requisite equipment. The laser subsystem is replaceable in the field by a qualified Customer Engineer. The laser chassis is not repairable in the field. Customer engineers are therefore directed to return all chassis and laser subsystems to the factory or service depot when replacement or the optical subsystem is required.

## **Important**

Contents of this manual are subject to change without prior notice. In no event will the company be liable for direct, indirect, special, incidental, or consequential damages as a result of handling or operating the machine.

## **Caution:**

Use of controls or adjustment or performance of procedures other than those specified in this manual might result in hazardous radiation exposure.

Do not attempt any maintenance or troubleshooting other than that mentioned in this manual. This printer contains a laser beam generator and direct exposure to laser beams can cause permanent eye damage.

Two kinds of size notation are employed in this manual. With this machine refer to the inch version.

For good copy quality, the supplier recommends that you use genuine toner from the supplier.

The supplier shall not be responsible for any damage or expense that might result from the use of parts other than genuine parts from the supplier with your office products.

# Trademarks

Microsoft, Windows, and Windows NT are registered trademarks of Microsoft Corporation in the United States and/or other countries.

IPS-PRINT© 1999-2000 Oak Technology, Inc., All rights reserved.

Ethernet is a registered trademark of Xerox Corporation.

Other product names used herein are for identification purposes only and might be trademarks of their respective companies. We disclaim any and all rights involved with those marks.

- The product name of Windows® 95 is Microsoft® Windows® 95.
- The product name of Windows® 98 is Microsoft® Windows® 98.
- The product name of Windows® Me is Microsoft® Windows® Millennium Edition (Windows Me).
- The product name of Windows® 2000 are as follows:  
Microsoft® Windows® 2000 Server  
Microsoft® Windows® 2000 Professional
- The product name of Windows NT® 4.0 are as follows:  
Microsoft® Windows NT® Server 4.0  
Microsoft® Windows NT® Workstation 4.0

---

## Notes:

---

Some illustrations in this manual might be slightly different from the machine.

Certain options might not be available in some countries. For more information, please contact your local dealer.

Fax options are not sold in some areas.

# Safety Information

When using your equipment, the following safety precautions should always be followed.

---

## Safety During Operation

---

In this manual, the following important symbols are used:

- |  |
|--|
| <p><b>⚠ WARNING:</b><br/><i>Indicates a potentially hazardous situation which, if instructions are not followed, could result in death or serious injury.</i></p> <p><b>⚠ CAUTION:</b><br/><i>Indicates a potentially hazardous situation which, if instructions are not followed, may result in minor or moderate injury or damage to property.</i></p> |
|--|

---

**⚠ WARNING:**

---

- |  |
|--|
| <ul style="list-style-type: none"><li>• <b>Confirm that the wall outlet is near the machine and freely accessible, so that in event of an emergency, it can be unplugged easily.</b></li><li>• <b>Disconnect the power plug (by pulling the plug, not the cable) if the power cable or plug becomes frayed or damaged.</b></li><li>• <b>To avoid hazardous electric shock or laser radiation exposure, do not remove any covers or screws other than those specified in this manual.</b></li><li>• <b>Turn off the power and disconnect the power plug (by pulling the plug, not the cable) if any of the following conditions exist:</b><ul style="list-style-type: none"><li>• <b>You spill something into the equipment.</b></li><li>• <b>You suspect that your equipment needs service or repair.</b></li><li>• <b>Your equipment's cover has been damaged.</b></li></ul></li><li>• <b>Do not incinerate spilled toner or used toner. Toner dust is flammable and might ignite when exposed to an open flame.</b></li><li>• <b>Disposal should take place at an authorized dealer or appropriate collection site.</b></li><li>• <b>If you dispose of the used toner cartridges yourself, dispose of them according to local regulations.</b></li></ul> |
|--|

---

**⚠ CAUTION:**

---

- *Protect the equipment from dampness or wet weather, such as rain, snow, and so on.*
- *You should take care that the power cable will not be damaged under the equipment.*
- *When you disconnect the power plug from the wall outlet, always pull the plug (not the cable).*
- *Do not allow paper clips, staples, or other small metallic objects to fall inside the equipment.*
- *Do not eat or swallow toner.*
- *Keep toner (used or unused) and toner cartridge out of reach of children.*
- *For environmental reasons, do not dispose of the equipment or expended supplies at a household waste collection point. Disposal should take place at an authorized dealer or an appropriate collection site.*
- *Our products are engineered to meet the highest standards of quality and functionality. When purchasing expendable supplies, we recommend using only those specified by an authorized dealer.*
- *The inside of the machine becomes very hot. Do not touch the parts with a label indicating a "hot surface". Touching a "hot surface" could result in a burn. (⚠: means "hot surface".)*
- *To install this machine, contact your service representative. It can be dangerous if electrical equipment is connected incorrectly.*
- *The service representative will install options. Do not loosen or remove any screws used in the rack.*

---

**Note**

---

- To move the machine, contact your service representative.
- The socket outlet on the back of the Scanner Unit is for the printer. Do not use it for other equipment.
- Power Connection: 120 V, 60 Hz, 12 A or more (10A: Printer, 2A: Copier System)
- For safety information, see also the Setup Guide.

# How to Read This Manual

---

## Symbols

---

In this manual, the following symbols are used:

 **WARNING:**

This symbol indicates a potentially hazardous situation which, if instructions are not followed, could result in death or serious injury.

 **CAUTION:**

This symbol indicates a potentially hazardous situation which, if instructions are not followed, may result in minor or moderate injury or damage to property.

\* The statements above are notes for your safety.

 **Important**

If this instruction is not followed, paper might be misfed, originals might be damaged, or data might be lost. Be sure to read this.

 **Preparation**

This symbol indicates the prior knowledge or preparations required before operating.

 **Note**

This symbol indicates precautions for operation, or actions to take after misoperation.

 **Limitation**

This symbol indicates numerical limits, functions that cannot be used together, or conditions in which a particular function cannot be used.

 **Reference**

This symbol indicates a reference.

[    ]

Keys that appear on the machine's panel display.

Keys and buttons that appear on the computer's display.

[    ]

Keys built into the machine's control panel.

Keys on the computer's keyboard.

# TABLE OF CONTENTS

## 1. Replacing Consumables and Maintenance Kit

---

Detaching the SR770 (2 Tray Finisher).....	1
Detaching the PT460 (Multi-bin).....	2
Opening and Closing the Duplex Reversal Unit.....	3
Replacing the Toner Cartridge.....	4
Replacing the Fusing Oil Unit.....	7
Replacing the Photoconductor Unit.....	11
Replacing the Development Unit.....	15
Replacing the Fusing Unit.....	19
Replacing the Dustproof Filter.....	23
Replacing the Used Toner Bottle.....	25
Replacing the Paper Feed Rollers.....	27

## 2. Clearing and Adjusting the Machine

---

Cautions to Take When Cleaning.....	31
Cleaning the Registration Roller.....	32
Cleaning the Dustproof Glass.....	33
Cleaning the Exposure Glass.....	34
Cleaning the Exposure Glass.....	34
Cleaning the Cover.....	35
When using the document feeder.....	35
When using the exposure glass cover.....	35
Adjusting the Color Registration.....	36
Auto Adjustment.....	36
Fuser Adjustment.....	37
Manual Adjustment.....	40
Test Sheet Samples.....	42
Adjusting the Color Calibration.....	45
Auto Color Calibration.....	45
Verifying the Test Pattern Sheet.....	47
Restoring Previous Color Calibration Settings.....	49
Adjusting the Registration of the Trays.....	50

## 3. Appendix

---

Removing Misfed Paper in the Duplex Feed Unit.....	53
Consumables.....	56
INDEX.....	58





# 1. Replacing Consumables and Maintenance Kit

## Detaching the SR770 (2 Tray Finisher)

There are times when you might have to detach the 2 Tray Finisher from the printer to remove misfed paper. This section describes how to detach the 2 Tray Finisher.

- 1** Hold the handle at the top of the 2 Tray Finisher firmly with one hand, and pull the 2 Tray Finisher straight out, until it stops.

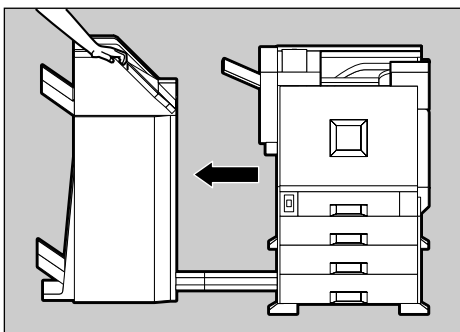

The 2 Tray Finisher is detached from the printer.

- 2** Use both hands to push it straight back in, until it clicks into place.

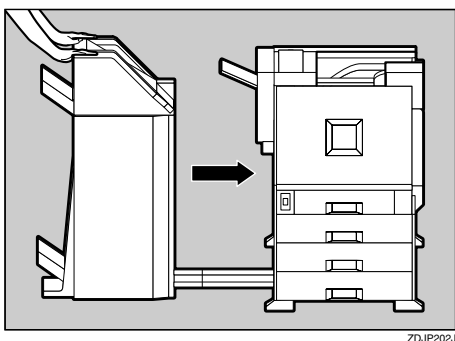

The 2 Tray Finisher is reattached to the printer.

### Important

- Be sure to attach the 2 Tray Finisher to the printer after closing the Duplex Reversal Unit. See p.3 "Opening and Closing the Duplex Reversal Unit".

# Detaching the PT460 (Multi-bin)

1

When replacing various units or removing misfed paper, the Duplex Reversal Unit is opened. If the optional PT460 (Multi-bin) is attached to the Duplex Reversal Unit, detach it before opening the Duplex Reversal Unit. After closing the Duplex Reversal Unit, reattach the optional PT460 (Multi-bin).

**1** Raise the External Tray attached to the Duplex Reversal Unit.

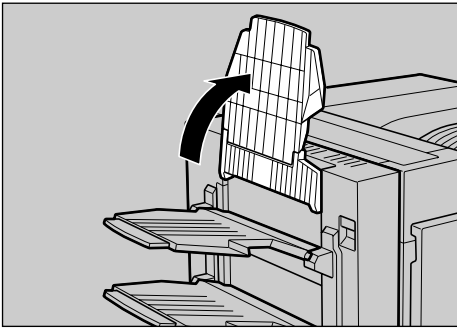

**2** Pull the upper tray of the PT460 (Multi-bin) out and up to detach it.

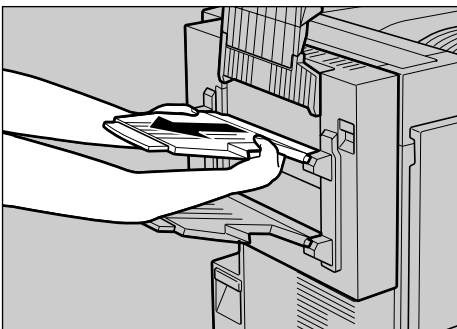

**3** Pull the lower tray of the PT460 (Multi-bin) out and up to detach it as in step **2**.

This completes the detachment of the PT460 (Multi-bin).

**4** Raise the External Tray attached to the Duplex Reversal Unit.

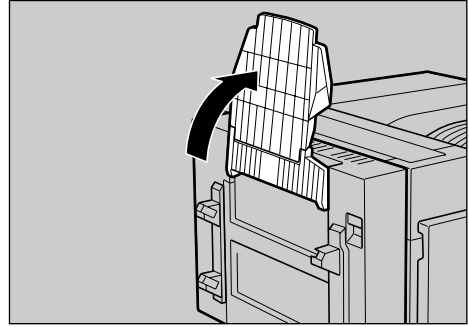

**5** Insert the hooks on both sides of the lower tray of the PT460 (Multi-bin) into the slots.

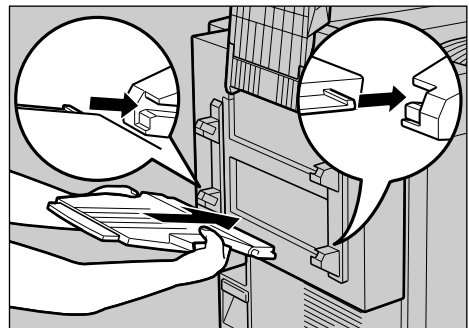

**6** Insert the hooks on both sides of the upper tray of the PT460 (Multi-bin) into the slots as in step **5**.

This completes the reattachment of the PT460 (Multi-bin) to the Duplex Unit.

# Opening and Closing the Duplex Reversal Unit

There are times when you might have to detach the Duplex Reversal Unit to remove misfed paper. This section describes how to detach the Duplex Reversal Unit.

- 1** Push up the lock release button and keep it in place.

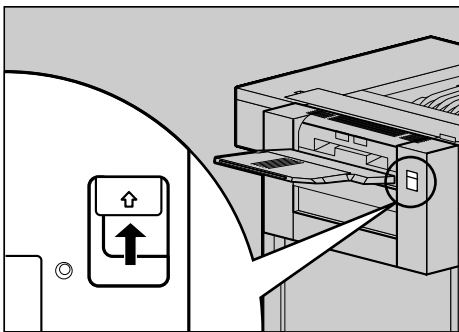

ZDJP203J

- 2** Lower the Duplex Reversal Unit slowly until it stops.

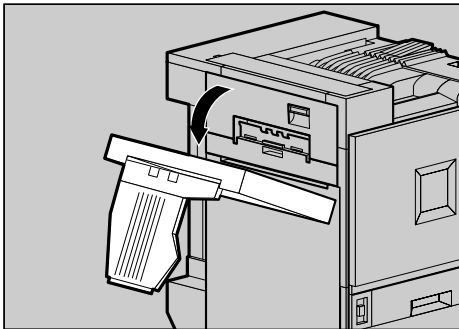

ZDJP204J

## Important

- ❑ Open the Duplex Reversal Unit after detaching the 2 Tray Finisher from the printer. See p.1 “Detaching the SR770 (2 Tray Finisher)”.

## Note

- ❑ You do not have to remove the External Tray even if the 2 Tray Finisher is attached.

The Duplex Reversal Unit is opened.

- 3** Raise the Duplex Reversal Unit slowly with both hands, and push it in until it clicks into place.

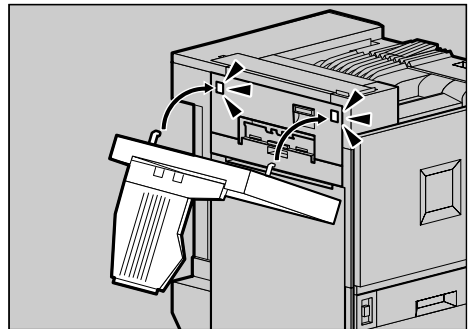

ZDJP205J

The Duplex Reversal Unit is closed.

## Important

- ❑ Attach the Duplex Reversal Unit after closing the upper left cover of the printer.

# Replacing the Toner Cartridge

1

**⚠ WARNING:**

- **Do not incinerate spilled toner or used toner. Toner dust is flammable and might ignite when exposed to an open flame. Disposal should take place at an authorized dealer or an appropriate collection site. If you dispose of the used toner cartridges yourself, dispose of them according to local regulations.**

**⚠ CAUTION:**

- *The inside of the machine becomes very hot. Do not touch the parts with a label indicating a "hot surface". Touching a "hot surface" could result in a burn.*
- *Keep toner (used or unused) and the toner cartridge out of reach of children.*
- *Our products are engineered to meet the highest standards of quality and functionality. When purchasing expendable supplies, we recommend using only those provided by an authorized dealer.*

**📎 Note**

- ❑ The actual number of printed pages will differ depending on the paper type, size, contents and settings. For more information, see p.56 "Toner cartridge".

If "Add Toner" or "Toner is almost empty." appears on the panel display, replace the toner cartridge.

**📎 Note**

- ❑ A combination of one to four colors, yellow, magenta, cyan, and black is displayed.
- ❑ If cyan, magenta or yellow toner runs out, you can print in black and white mode using the black toner. Change the color mode setting to "Black and White" from the printer driver .
- ❑ If black toner runs out, printing is not possible until the black toner cartridge is replaced.

- 1** While pushing the lock button on the upper right cover of the printer (①), open the upper right cover (②).

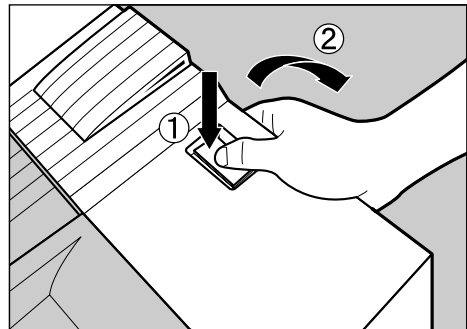

From the end, the toner cartridges are installed in the order of magenta (M), cyan (C), yellow (Y), and black (K).

- 2** Remove the toner cartridge for the color you want to replace.

**📎 Note**

- ❑ The method to remove a toner cartridge is the same for all four cartridges.

- 1 Unhook the green hook on the toner cartridge with one hand.

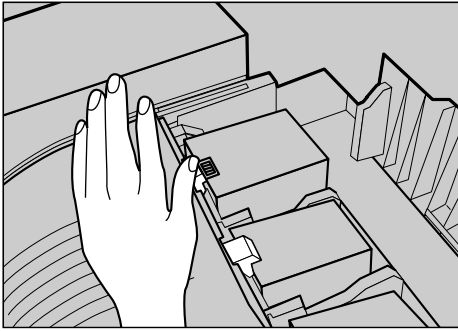

ZDJT999J

- 2 Holding the toner cartridge with the other hand, pull out the cartridge up slowly.

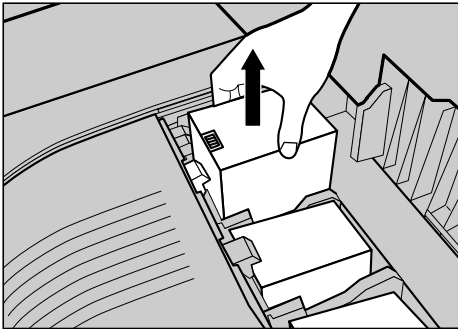

ZDJT201J

**Important**

- Do not shake the removed toner cartridge. The remaining toner might scatter.

- 3 Take out the new toner cartridge from the box.

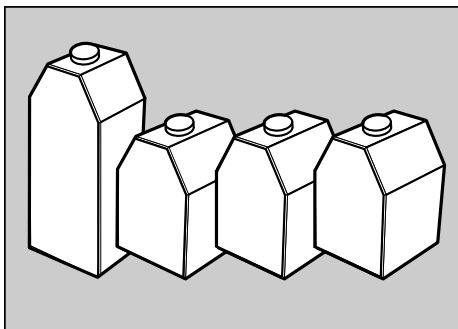

ZDJT202J

**Note**

- The black toner cartridge contains more than the other toner cartridges.

- 4 Shake the toner cartridge back and forth 5-6 times.

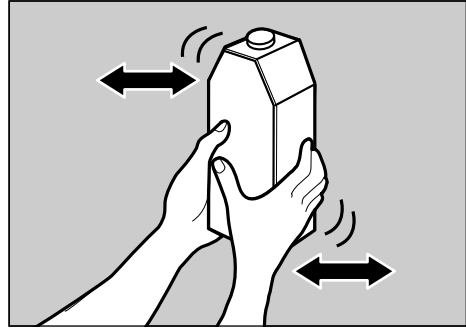

ZDJT203J

- 5 Holding the toner cartridge with the metal contact area in front, attach it in the direction of the arrow.

**Note**

- The method to replace a toner cartridge is the same for all four cartridges.

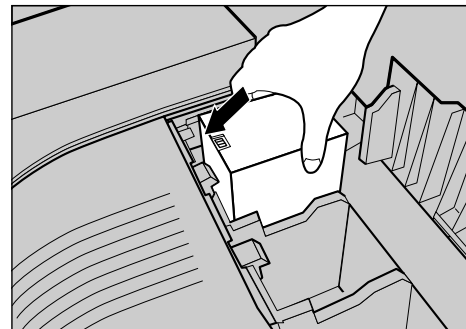

ZDJT004J

**Important**

- Do not touch the metal contact point with your fingers.

- 6** Insert the toner cartridge slowly until the green hook snaps on the metal contact area.

1

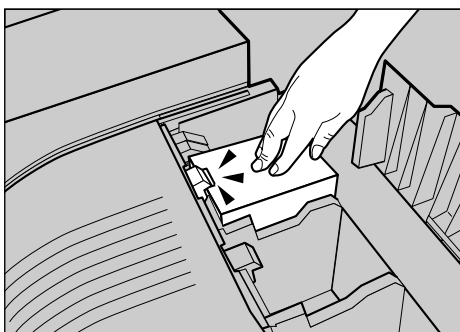

ZDJT005J

**Important**

- Do not install and remove the toner cartridges over and over. This could result in a toner leak.

- 7** Close the upper right cover.

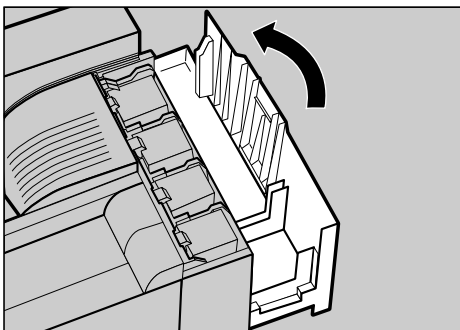

ZDJH042J

Please wait a while.

**Important**

- Do not turn off the power switch when "Loading Toner" is shown on the panel display. This will cause a printer malfunction.

# Replacing the Fusing Oil Unit

## ⚠ CAUTION:

- The Fusing Unit becomes very hot. When installing the new Fusing Oil Unit, turn off the printer and wait about an hour. After that, install the new Fusing Unit. Not waiting for the unit to cool down can result in a burn.

If "Fusing Oil Unit Replacement" appears on the panel display, replace the Fusing Oil Unit.

- 1 Turn off the power switch, and then unplug the power cable.

### ⚡ Important

- Be sure to wait about an hour to prevent a burn.

- 2 If the 2 Tray Finisher is installed, detach it from the printer.

### 🔍 Reference

See p.1 "Detaching the SR770 (2 Tray Finisher)".

- 3 If the Duplex Unit is installed, open the Duplex Reversal Unit.

### 📎 Note

- If the PT460 (Multi-bin) is attached to the Duplex Reversal Unit, detach it before opening the Duplex Reversal Unit.

### 🔍 Reference

See p.3 "Opening and Closing the Duplex Reversal Unit".

- 4 If the External Tray is attached to the printer, raise it in the direction of the arrow (①), and remove it (②).

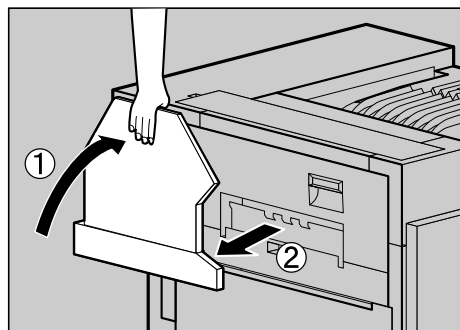

- 5 Pull out the left cover of the printer slowly.

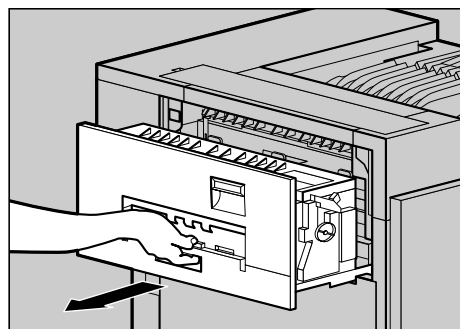

- 6 Open the upper left cover.

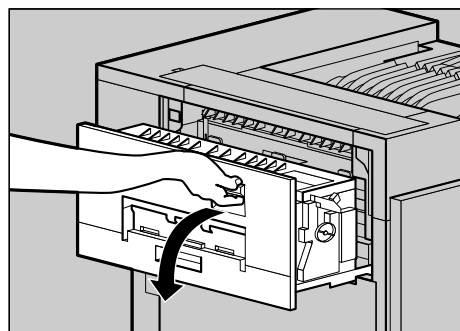

**7** Holding the green handle, pull up the Fusing Unit slowly in the direction of the arrow.

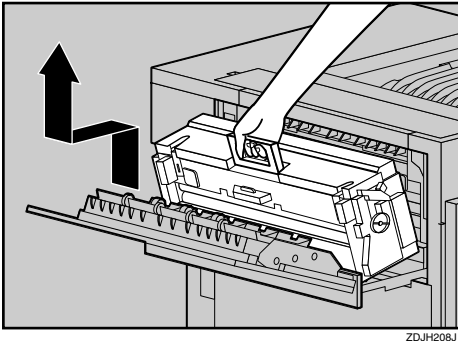

ZDJH208J

**Important**

- Do not touch any areas other than the handle.

**8** Put the removed Fusing Unit in a stable and level place.

**9** Lift the Fusing Oil Unit in the direction of the arrow to remove it, and put it in a stable and level place.

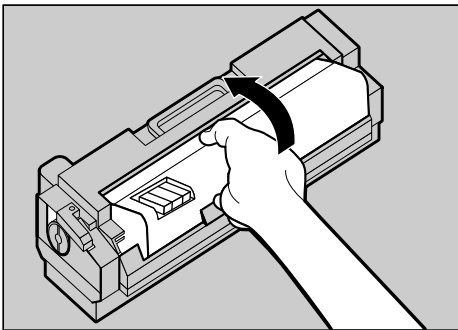

ZDJH052E

**Important**

- Do not touch the inside of the Fusing Unit.
- Be careful not to touch the area other than that shown in the illustration.

**10** Take out the new Fusing Oil Unit from the bag, remove seal (①), and then remove seal (②) as shown in the illustration.

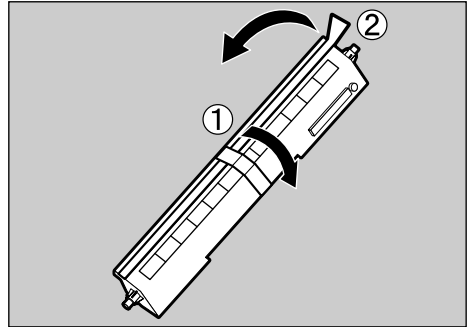

ZDJH053J

**Note**

- Be sure to remove seal (①), and then pull it out in a level manner.

**Important**

- Be sure to remove the seals to avoid printer malfunction.
- Be sure to remove seal (①) first, and then remove seal (②) to avoid an oil leak.
- Be sure to put the Fusing Oil Unit in a stable and level place to avoid an oil leak.
- There is oil on the removed seals and fuser oil roller. Be careful not to let them come in contact with your clothes.



- 11** Match (▲) on the front of the Fuser Oil Unit and the arrow on the Fusing Unit as shown in the illustration.

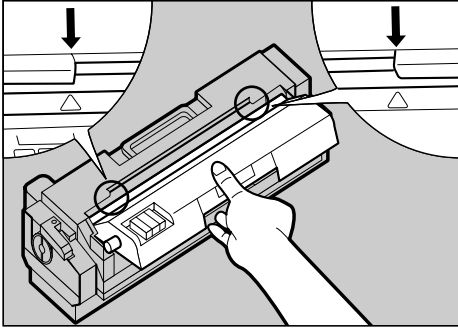

ZDJH055J

**Important**

- Be careful not to get oil on the metal part of the left side of the Fuser Oil Unit.

- 12** Insert the left and right protrusions of the Fuser Oil Unit into the white holders of the Fusing Unit (①), and then move the Fuser Oil Unit in the direction shown by the arrow (②) to attach the Fuser Oil Unit to the Fusing Unit.

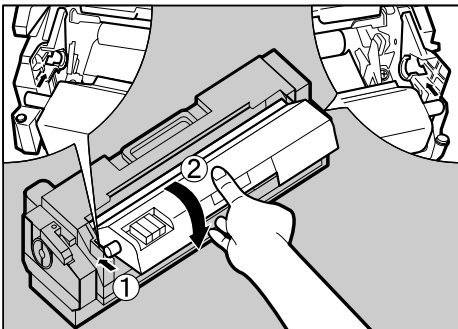

ZDJH054J

- 13** Holding the green handle with one hand, use your other hand to push the front area of the handle to create a slight slant, and push the Fusing Unit slowly to the back.

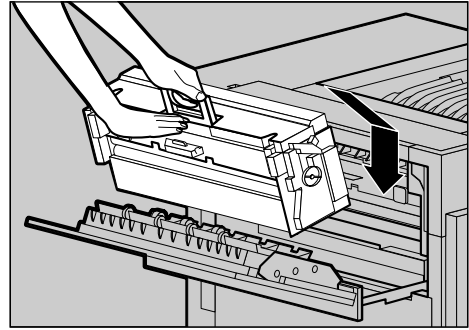

ZDJH050E

**Note**

- Confirm that the Fusing Oil Unit is facing the inside of the printer.

At this point, make sure the Fusing Unit is on the stand properly.

- 14** Close the upper left cover (①), and then push the handle slowly (②) to the back until it clicks into place.

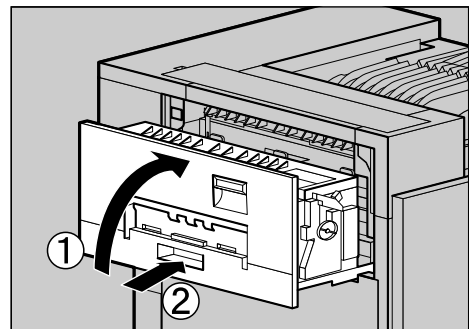

ZDJH051J

- 15** Place the old Fusing Oil Unit into the bag which contained the new Fusing Oil Unit, and seal the bag.

- 16** If you removed the External Tray in step 4, reattach it to the printer. Insert the hooks of the External Tray into the printer slits, and lower it toward you.

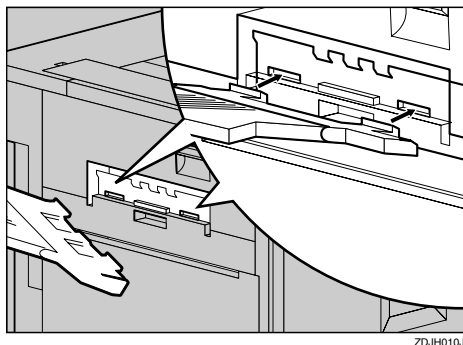

- 17** If the Duplex Unit is installed, close the Duplex Reversal Unit.

 **Note**

- If the PT460 (Multi-bin) is attached to the Duplex Reversal Unit, detach it before opening the Duplex Reversal Unit.

 **Reference**

See p.3 “Opening and Closing the Duplex Reversal Unit”.

- 18** If the 2 Tray Finisher was installed, reattach the 2 Tray Finisher to the printer.

 **Reference**

See p.1 “Detaching the SR770 (2 Tray Finisher)”.

- 19** Plug in the power cable, and then turn on the power switch.

 **Note**

- If you dispose of the used toner cartridges by yourself, dispose of them according to local regulations.

# Replacing the Photoconductor Unit

If the message "Replacement Photoconductor Unit is required" or "Replace Photoconductor Unit" appears on the panel display, replace the appropriate Photoconductor Unit according to the indicated colors.

## Note

- ❑ The Photoconductor Unit or units to be replaced are indicated on the panel display.
- ❑ If "Black" appears, replace the black Photoconductor Unit.
- ❑ If "yellow/magenta/cyan" appears, replace the three color (CMY) Photoconductor Units.

**1** Turn off the power switch, and then unplug the power cable.

**2** Open the front cover slowly by pulling down from the two areas on the left and right.

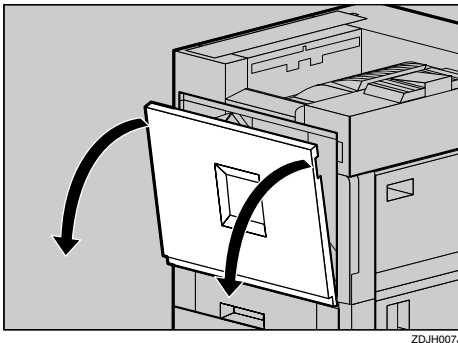

**3** Take out the green screwdriver.

Use this screwdriver to attach and detach all screws.

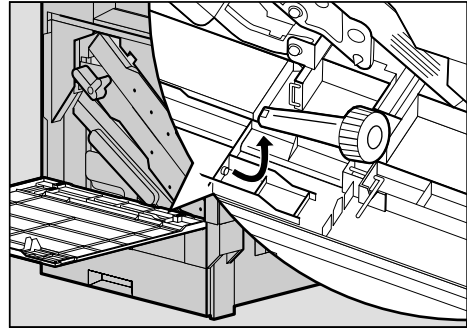

**4** Turn the light brown lever counterclockwise.

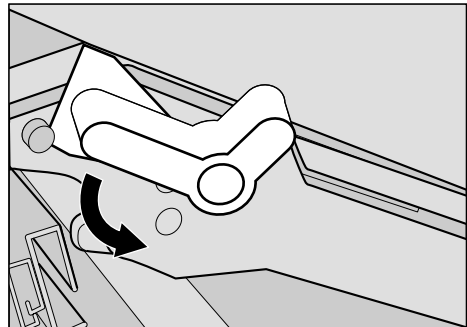

**5** Loosen the two screws that fasten the inner cover using the provided screwdriver.

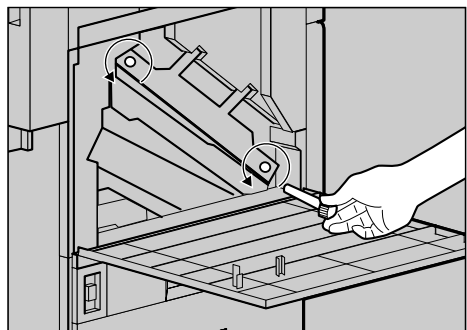

You cannot remove these two screws.

- 6** Lift the inner cover until it clicks into place and holds.

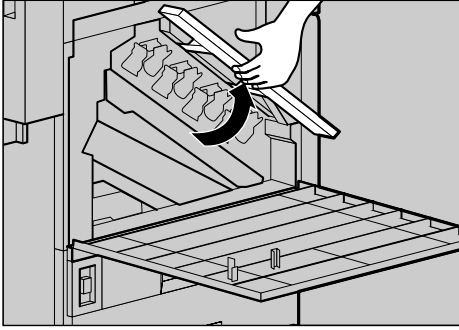

ZDJH016J

The Photoconductor Units are installed as shown in the illustration. The black Photoconductor Unit is the upper left one. The other three are color Photoconductor Units.

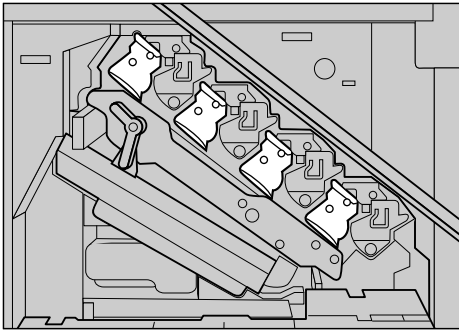

ZDJH045J

- 7** Remove the Photoconductor Unit you want to replace.

For black, remove the upper left one, and for color, remove the three on the right.

- 1** Move the green hook slowly to the right as shown in the illustration. The green hook is located on the upper right of the Photoconductor Unit.

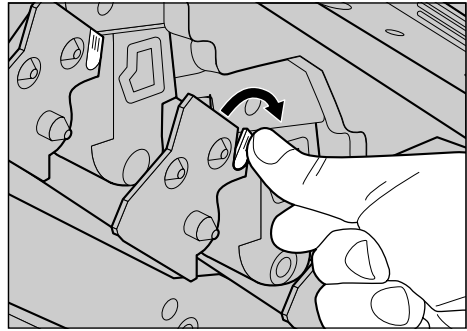

ZDJX701J

- 2** Grip the green areas at the top and bottom of the Photoconductor Unit, and pull slowly until you can see all of the green handle.

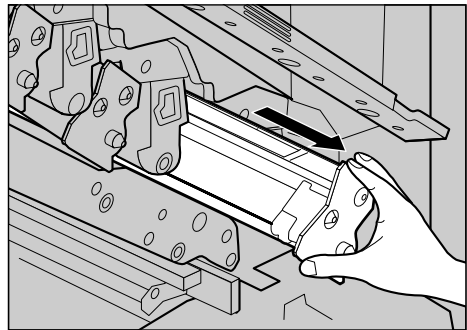

ZDJH211J

**Important**

- Pulling out the Photoconductor Unit quickly might cause it to drop.

- 3** Lift and hold the green handle at the top (1), and pull out the unit slowly (2).

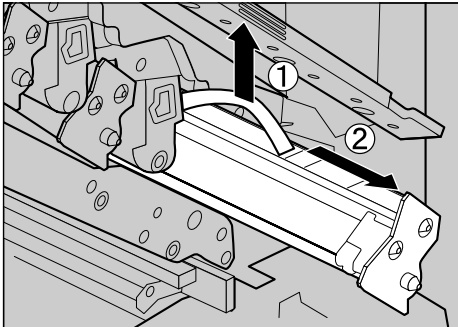

ZDJH210J

- 2** Place the Photoconductor Unit in your hand, and remove the adhesive tape at the tip of the unit.

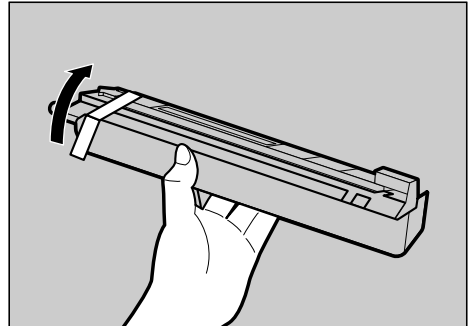

ZDJH222J

- 8** Install the new Photoconductor Unit.

For black, install one, and for color, install three.

- 1** Take the unit out from the bag.

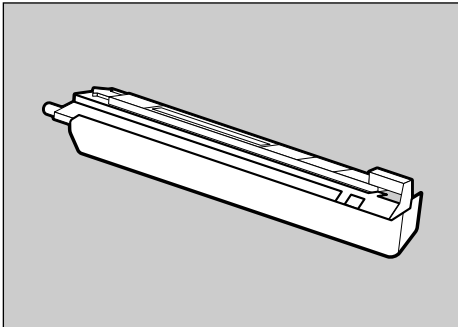

ZDJH221J

- 3** Match the green arrow at the tip of the Photoconductor Unit to the rail inside the printer.

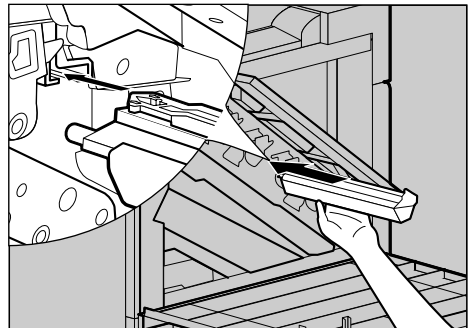

ZDJH223J

**Important**

- Do not remove the cover that is attached to the bottom of the Photoconductor Unit at this time.

**Important**

- Make sure the green arrow fits securely on the rail before proceeding to the next step.

- 4** Push the front of the Photoconductor Unit slowly, slide the unit on the cover, and push in until it stops.

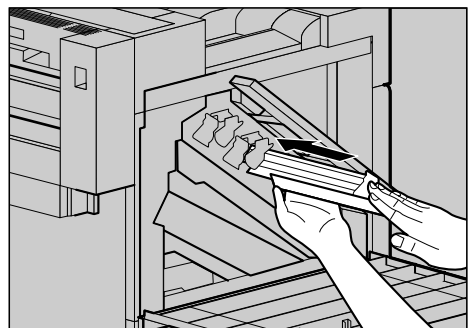

ZDJH224J

**Important**

- ❑ If you do not attach the green arrow of the Photoconductor Unit securely to the rail, you might damage the Photoconductor Unit.
- ❑ Do not touch the light-sensitive area of the Photoconductor Unit.

**5** Remove the cover and push in the Photoconductor Unit until it stops.

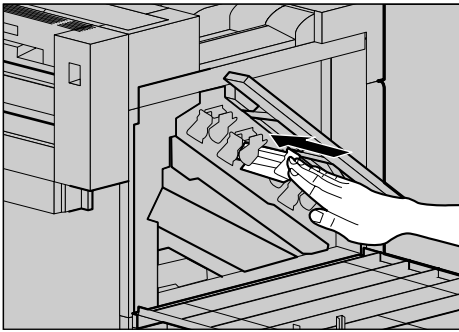

ZDJX702E

**9** Lower the inner cover slowly.

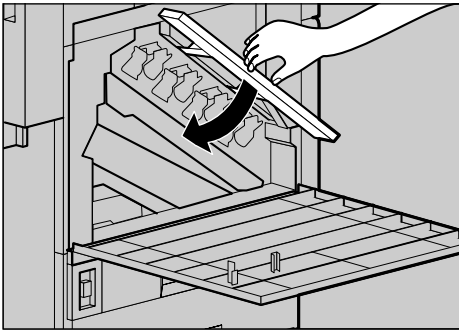

ZDJH018J

**10** Tighten the two screws using the provided screwdriver.

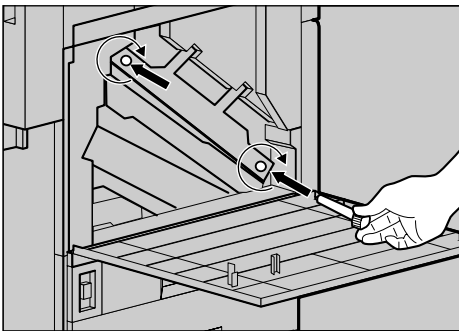

ZDJH019J

**Note**

- ❑ Be sure to return the provided screwdriver to its original position on the back of the front cover.

**11** Turn the light brown lever clockwise.

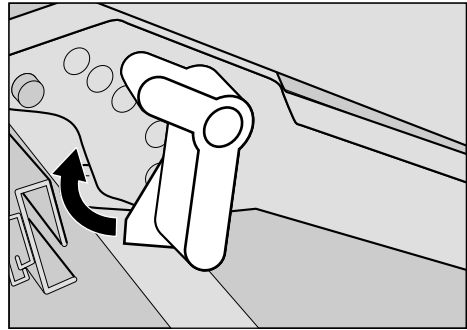

ZDJH020E

**12** Close the front cover slowly by pushing the two areas on the left and right.

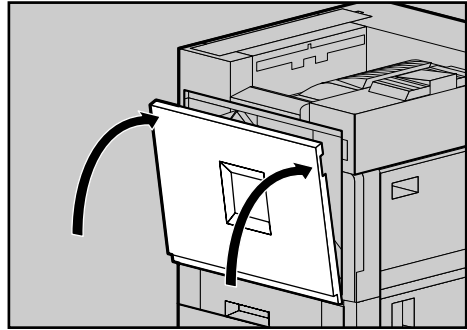

ZDJH041J

**13** Plug in the power cable, and then turn on the power switch.

“Color is being adjusted” appears on the panel display. The printer starts calibration. Please wait until it stops.

**Important**

- ❑ Do not turn off the power switch while calibration. This will cause a printer malfunction.

# Replacing the Development Unit

If the message "Replacement of Development Unit is required" appears on the panel display, replace the appropriate Development Unit according to the indicated colors.

## Note

- ❑ The Development Unit or units to be replaced are indicated on the panel display.
- ❑ If "Black" appears, replace the black Development Unit.
- ❑ If "yellow/magenta/cyan" appears, replace the three color (CMY) Development Units.

## Note

- ❑ A dustproof filter is attached to the black Development Unit. When replacing the black Development Unit, also replace the dustproof filter. See p.23 "Replacing the Dustproof Filter".
- ❑ When replacing the black Development Unit, clean the registration roller. See p.32 "Cleaning the Registration Roller".

**1** Turn off the power switch, and then unplug the power cable.

**2** Open the front cover slowly by pulling down from the two areas on the left and right.

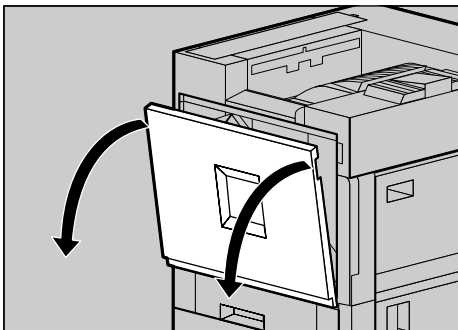

ZDJH007J

**3** Take out the green screwdriver.

Use this screwdriver to attach and detach all screws.

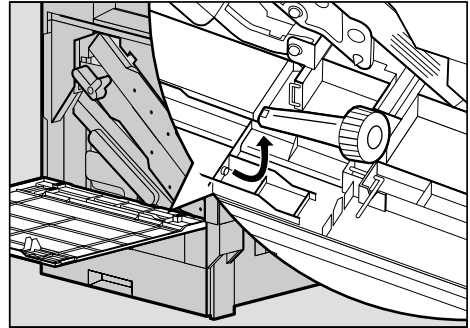

ZDJH013J

**4** Turn the light brown lever counterclockwise.

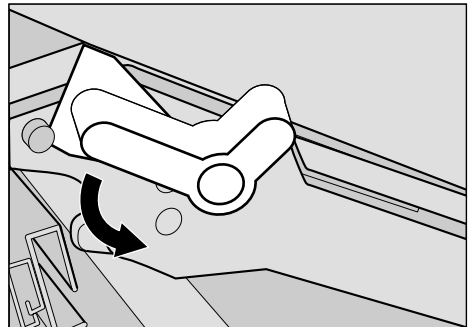

ZDJH014E

**5** Loosen the two screws that fasten the inner cover using the provided screwdriver.

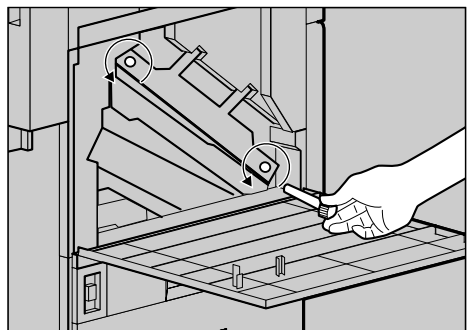

ZDJH015J

You cannot remove these two screws.

- 6** Lift the inner cover until it clicks into place and holds.

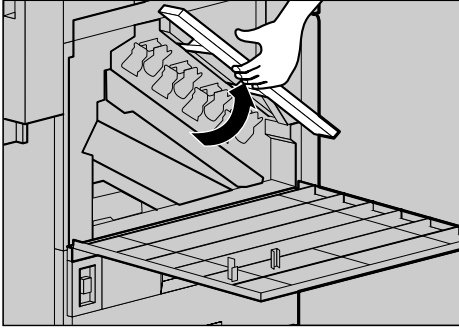

ZDJH016J

The Development Units are installed as shown in the illustration. Starting from the upper left, the units are installed in the order of black (K), yellow (Y), cyan (C), and magenta (M).

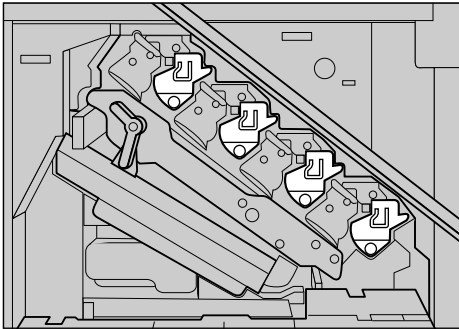

ZDJH046J

- 7** Remove the Development Unit.

The procedure for removing the unit is the same for all four colors.

- 1** Hook your finger on the green tab in front of the Development Unit you want to replace, and pull it out halfway.

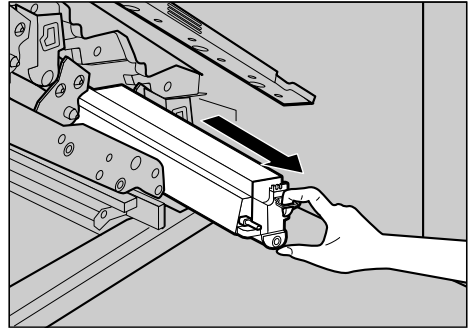

ZDJH225J

**Important**

- Pulling out the Development Unit quickly might cause it to drop.

- 2** Hold the right side of the Development Unit, and pull out the unit slowly.

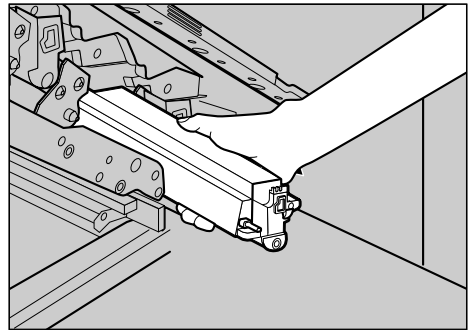

ZDJH993J

**Important**

- Be careful not to touch the right side of the Photoconductor Unit with your hands or clothes.



## 8 Install the new Development Unit.

The procedure for attaching the Development Unit is the same for all four colors.

### 1 Take the unit out from the bag.

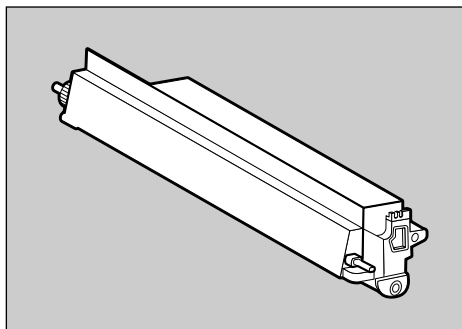

ZDJH226J

### 2 Insert the Development Unit along the rail, and push in slowly until it stops.

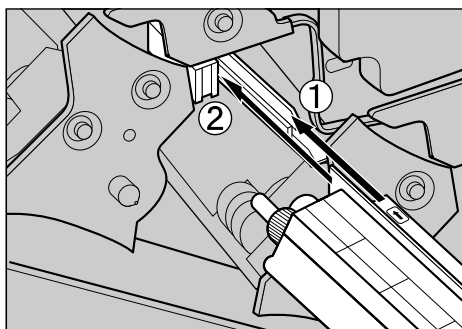

ZDJH227J

### 3 Holding the Development Unit, pull out the tape slowly in a level manner.

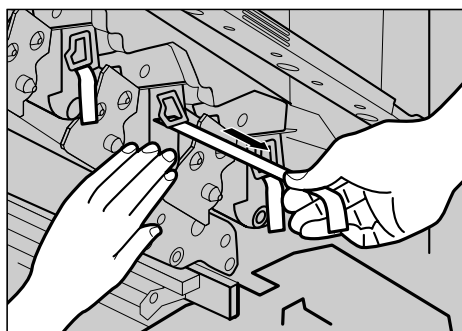

ZDJH039J

## Important

- Be sure to pull out the tape to avoid printer malfunction during operation.
- The removed tape is dirty. Be careful not to let it get in contact with your hands or clothes.

### 9 Lower the inner cover slowly.

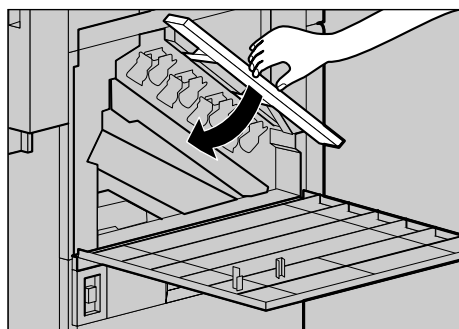

ZDJH018J

### 10 Tighten the two screws using the provided screwdriver.

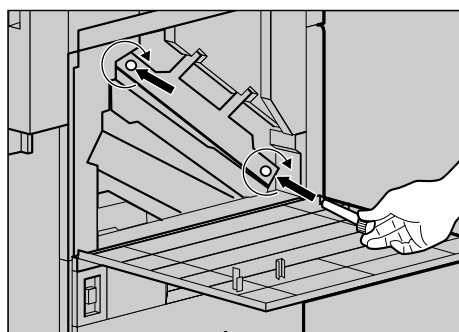

ZDJH019J

## Note

- Be sure to return the provided screwdriver to its original position on the inside of the front cover.

- 11 Turn the light brown lever clockwise.

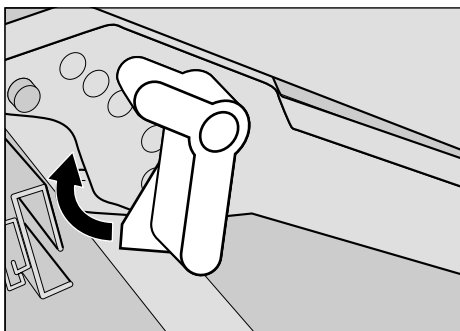

ZDJH020E

- 12 Close the front cover slowly by pushing the two areas on the left and right.

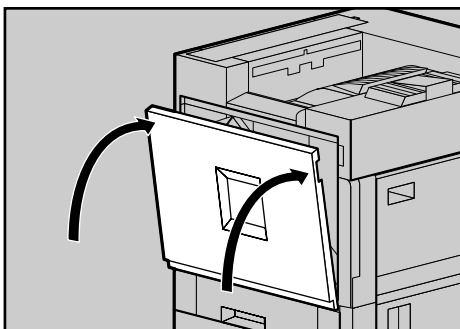

ZDJH041J

- 13 Plug in the power cable, and then turn on the power switch.

"Please Wait " appears on the panel display, and initial adjustments begin. Please wait until it stops.

**Important**

- Do not turn off the power switch while calibration. This will cause a printer malfunction.

# Replacing the Fusing Unit

## ⚠ CAUTION:

- The Fusing Unit becomes very hot. When installing the new Fusing Unit, turn off the printer and wait about an hour. After that, install the new Fusing Unit. Not waiting for the unit to cool down can result in a burn.

If "Fusing Unit Replacement" appears on the panel display, replace the Fusing Unit.

- 1 Turn off the power switch, and then unplug the power cable.

### ⚠ Important

- Be sure to wait about an hour to prevent a burn.

- 2 If the 2 Tray Finisher is installed, detach it from the printer.

### 🔍 Reference

See p.1 "Detaching the SR770 (2 Tray Finisher)".

- 3 If the Duplex Unit is installed, open the Duplex Reversal Unit.

### 📎 Note

- If the PT460 (Multi-bin) is attached to the Duplex Reversal Unit, detach it before opening the Duplex Reversal Unit.

### 🔍 Reference

See p.3 "Opening and Closing the Duplex Reversal Unit".

- 4 If the External Tray is attached to the printer, raise it in the direction of the arrow (①), and remove it (②).

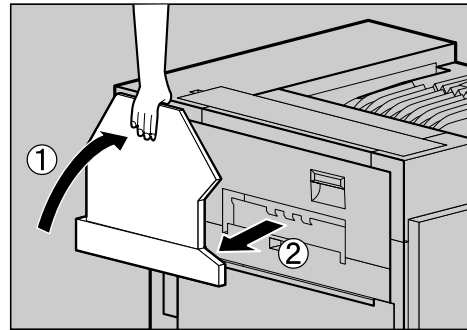

ZD.JP038J

- 5 Pull out the left cover of the printer.

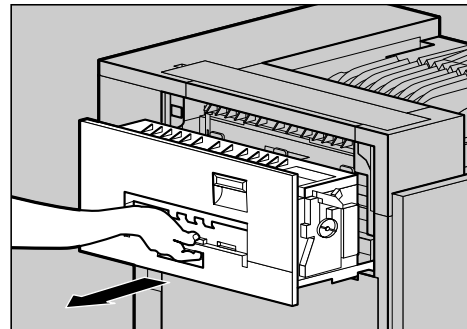

ZD.JH047J

- 6 Open the upper left cover.

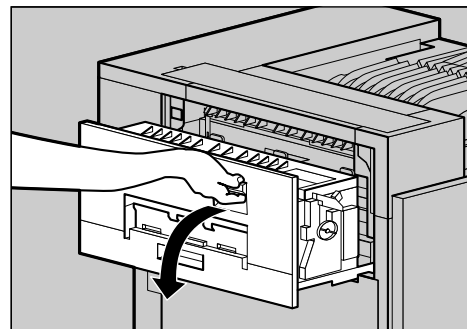

ZD.JH048J

### ⚠ Important

- Do not touch any areas other than the handle.

**7** Holding the green handle, pull up the Fusing Unit slowly in the direction of the arrow, and then put it in a stable and level place.

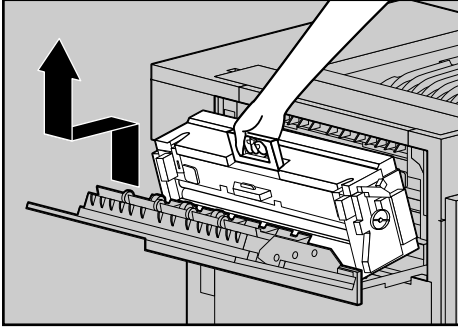

ZDJH208J

**8** Take out the new Fusing Unit from the bag and put it in a stable and level place.

**Important**

- The A3 paper which comes with the new Fusing Unit will be used in a later step 20, so be careful not to lose it.
- Do not turn the blue dial at the side of the new fusing unit when replacing it or before turning on the power switch.

**9** Remove the Fusing Oil Unit in the direction of the arrow.

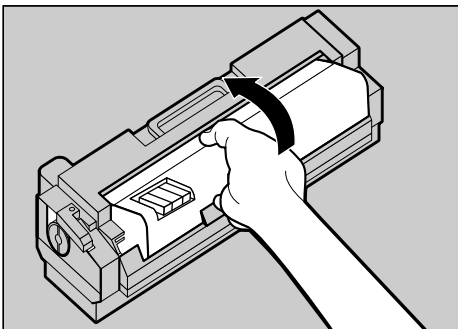

ZDJH052E

**Important**

- Do not touch the inside of the Fusing Unit.
- Be careful not to touch the oil.

**10** Match (▲) on the front of the Fuser Oil Unit and the arrow on the Fusing Unit as shown in the illustration.

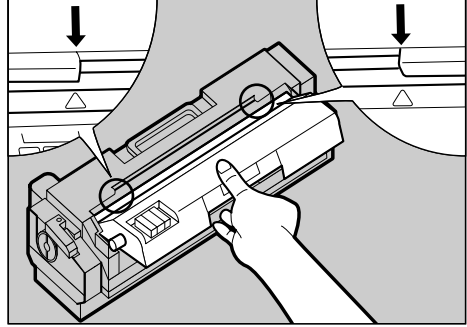

ZDJH055J

**Important**

- Be careful not to get oil on the metal part of the left side of the Fuser Oil Unit.

**11** Insert the left and right protrusions of the Fuser Oil Unit into the white holders of the Fusing Unit (①), and then move the Fuser Oil Unit in the direction shown by the arrow (②) to attach the Fuser Oil Unit to the Fusing Unit.

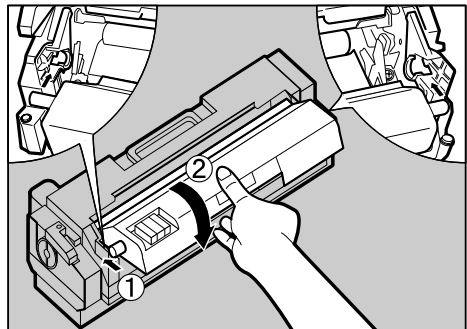

ZDJH054J

**Important**

- Be careful not to get oil on the metal part of the left side of the Fusing Oil Unit

**12** Put the removed Fusing Oil Unit in the bag that enclosed the new Fusing Unit, and then seal it.

- 13** Holding the green handle of the new Fusing Unit, use your other hand to push the area right in front of the handle to create a slight slant, and then push the Fusing Unit slowly to the back.

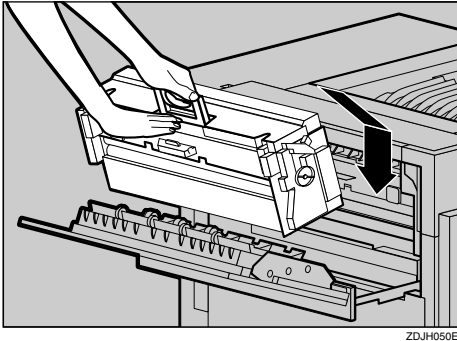

### Important

- Confirm that the Fusing Oil Unit is facing the inside of the printer.
- Confirm that the Fusing Unit is properly positioned in the machine.

- 14** Close the upper left cover (①) and push the handle (②) slowly to the back until it clicks into place.

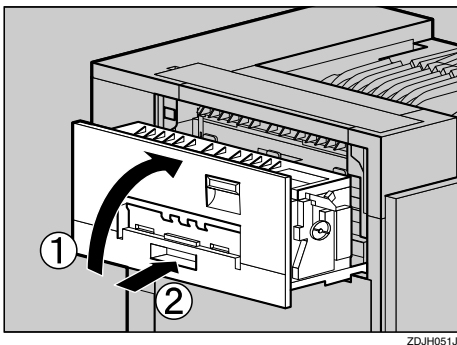

- 15** If you removed the External Tray in step 4, reattach it to the printer. Insert the hooks of the External Tray into the printer slits, and lower it toward you.

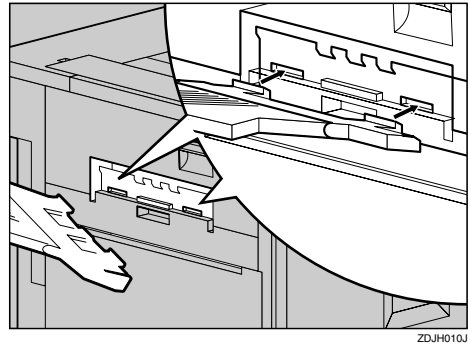

- 16** If the Duplex Unit is installed, close the Duplex Reversal Unit.

### Note

- If the PT460 (Multi-bin) is attached to the Duplex Reversal Unit, detach it before opening the Duplex Reversal Unit.

### Reference

See p.3 "Opening and Closing the Duplex Reversal Unit".

- 17** If the 2 Tray Finisher was installed, reattach the 2 Tray Finisher to the printer.

### Reference

See p.1 "Detaching the SR770 (2 Tray Finisher)".

- 18** Plug in the power cable, and then turn on the power switch.

- 19** After you replace the Fuser Unit, the message "After replacing Fuser Unit, Fuser Adjustment needs to be performed. Press [OK] to begin the adjustment" appears. You must now carry out the Fuser Adjustment procedure.

**Note**

If the toner has almost run out or Auto Adjustment has not finished, the Fuser Adjustment procedure cannot be carried out. Carry out the Fuser Adjustment procedure after replenishing the toner or after Auto Adjustment has finished.

**20** Load the A3 paper that comes with the new Fusing Unit in the Bypass Tray, and then press [Start Printing].



The printer prints 8 Test Sheets (A-H).

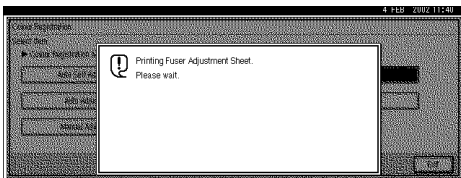

**21** After printing the Fuser Adjustment Sheet, the Fuser Adjustment display appears. Adjust the print settings for boxes A - H on the Fuser Adjustment Sheet.

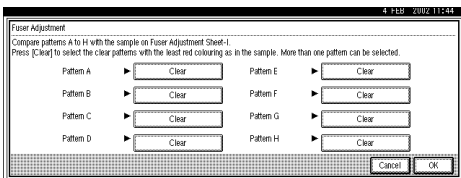

**Note**

Check the printed Fuser Adjustment Sheet to adjust the print settings.

**1** Compare box A of the pattern with the white square in the printed Fuser Adjustment Sheet. If the pattern is the same as the printed Fuser Adjustment Sheet, press [Clear]. If it is not, do not press [Clear].

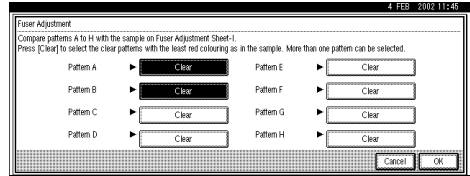

**Note**

If you press [Clear] again, setting will be cancelled.

**2** Repeat step 1 to make the settings for boxes B to H.

**3** After making all the settings, press [OK].

**Note**

If [Clear] is not pressed for one of the boxes, the following display appears. Press [Exit] and repeat the procedure from step 1.

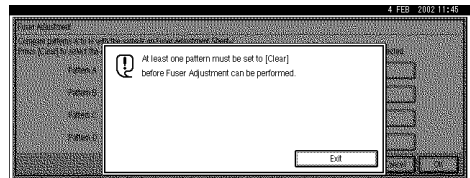

**22** After making all the settings, press the [User Tools/Counter] key. The initial display is shown.

# Replacing the Dustproof Filter

The dustproof filter is attached to the black Development Unit. When replacing the black Development Unit, also replace the dustproof filter.

The dustproof filter is attached to the left side of the printer shown in the illustration.

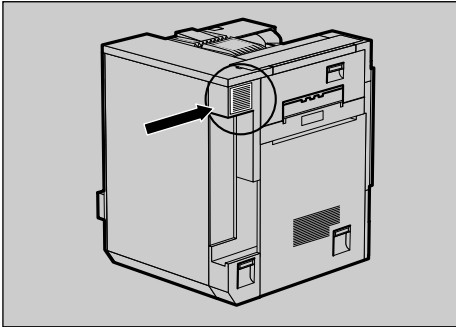

- 1** Turn off the power switch, and then unplug the power cable.
- 2** Push in the grips on both sides of the dustproof filter cover to pull it off.

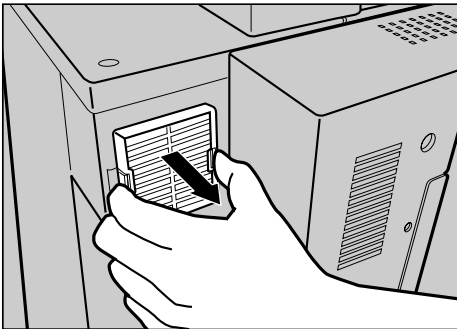

## Note

- Be sure to put the removed dustproof filter cover in a stable and level place.

- 3** From the box which contained the black Development Unit, take out the new dustproof filters and glove.

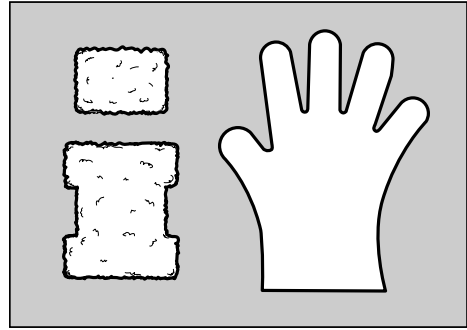

- 4** Wear the glove on either hand.

1

**5** With the hand wearing the glove, take out the dustproof filters that are attached to the dustproof filter cover slowly, one by one, and put them into the box which contained the black Development Unit.

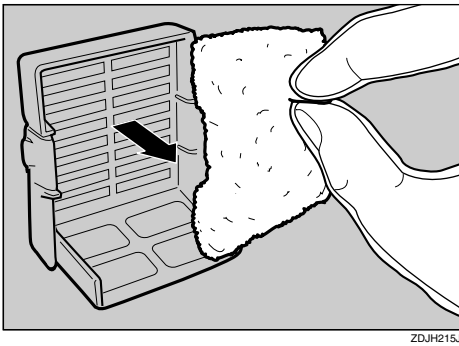
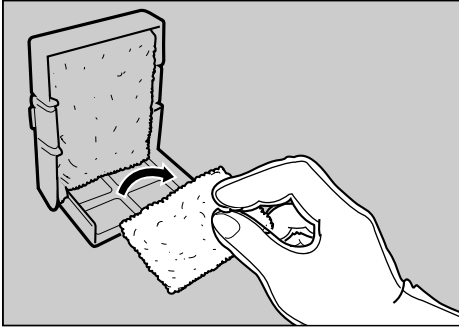

**Important**

- Handle the removed dustproof filters with care. If you shake them, the attached dust might scatter.
- Be sure to remove the glove to attach the new dustproof filter.

**6** Attach the new dustproof filters to the dustproof filter cover one by one.

**1** Attach the large filter.

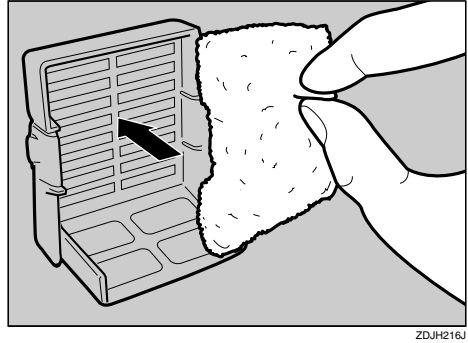

**2** Attach the small filter.

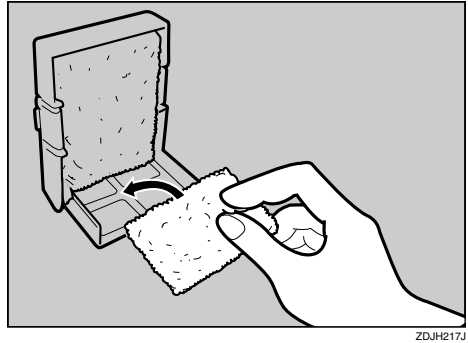

**7** Insert the dustproof filter cover into the upper left area of the printer.

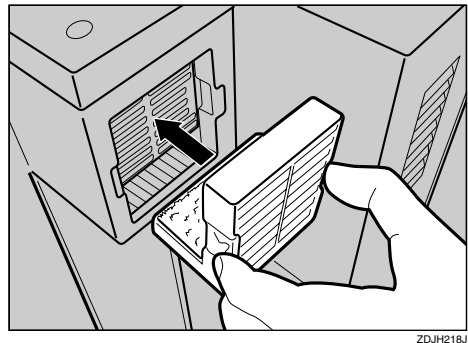

**8** Plug in the power cable, and then turn on the power switch.



# Replacing the Used Toner Bottle

If "Used Toner Bottle Replacement" appears on the panel display, replace the used toner bottle.

**1** Turn off the power switch, and then unplug the power cable.

**2** Open the front cover slowly by pulling down from the two areas on the left and right.

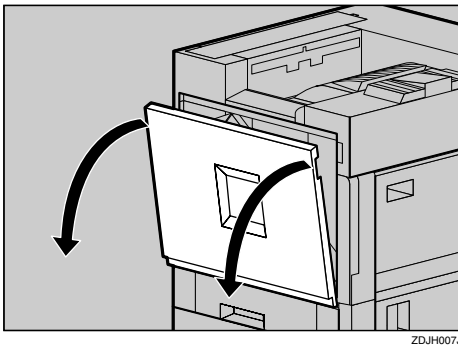

ZDJH007J

**3** Take out the new used toner bottle from the bag.

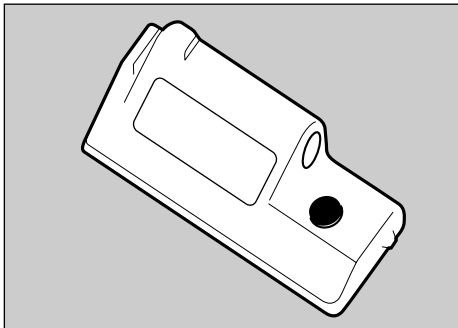

ZDJH228J

**4** Remove the used toner bottle slowly from inside the printer.

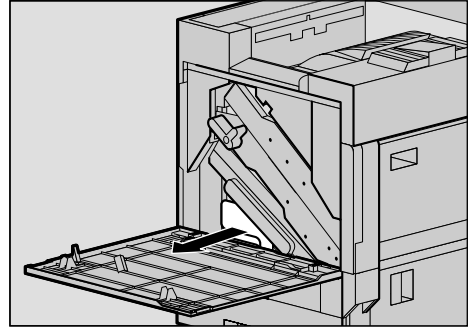

ZDJH802J

## ⚠ Important

- Be sure to remove the used toner bottle in a level manner.

**5** Remove the lid (①), and then put it on the place shown in the illustration (②).

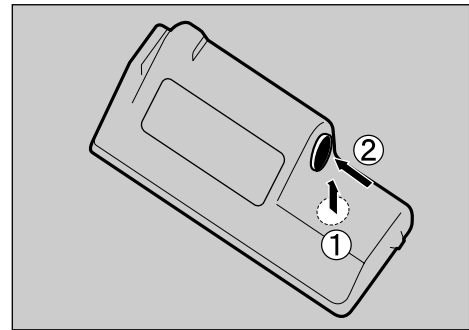

ZDJH229J

**6** Put the used toner bottle into the bag that contained the new used toner bottle, and then seal the bag.

## ⚠ Important

- Be sure to handle the bottle carefully so the waste toner does not spill.

**7** Insert the new used toner bottle in the position shown in the illustration.

**10** Plug in the power cable and turn on the power switch.

1

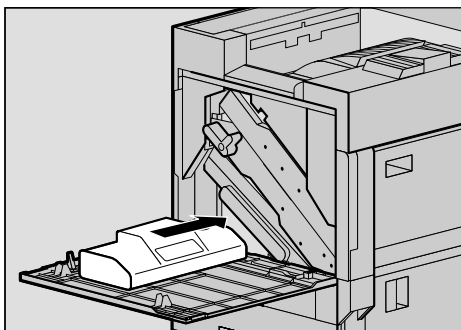

**8** Push it in until it stops.

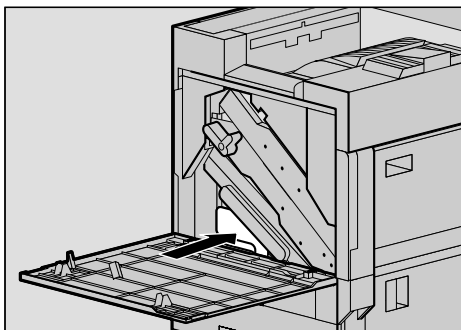

**Important**

- Be sure to insert the used toner bottle firmly to avoid toner leaking inside the printer.

**9** Close the front cover slowly by pushing the two areas on the left and right.

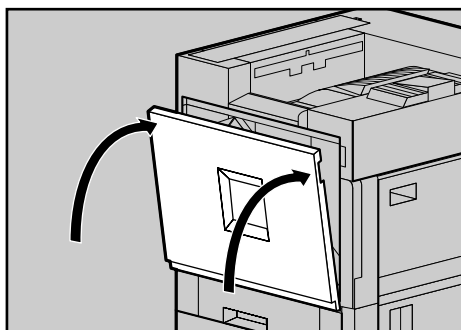

# Replacing the Paper Feed Rollers

**⚠ CAUTION:**

- The inside of the machine becomes very hot. Do not touch the parts with a label indicating a "hot surface". Touching a "hot surface" could result in a burn.

**🔧 Note**

- ❑ The following illustrations are for replacing the paper feed rollers of Tray 1. The same procedure is followed with the other trays.

**1** Check the contents of the box.

❖ Paper Feed Roller A

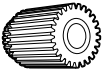

❖ Paper Feed Roller B

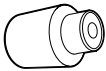

❖ Paper Feed Roller C



❖ Two Stoppers



**2** Turn off the power switch, and then unplug the power cable and interface cable.

**⚡ Important**

- ❑ If you replace the paper feed rollers of the optional 2000-sheet Large Capacity Tray, remove all paper from the tray.

**3** Pull out all trays slowly while lifting them up a little.

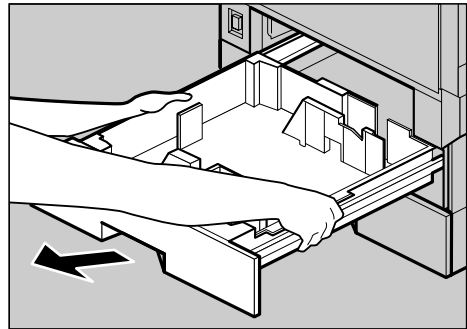

ZERH010E

**🔧 Note**

- ❑ If you replace the paper feed rollers of the optional Paper Feed Unit or 2000-sheet Large Capacity Tray, pull out all the paper trays from each unit.

**4** Confirm the position of the paper feed rollers.

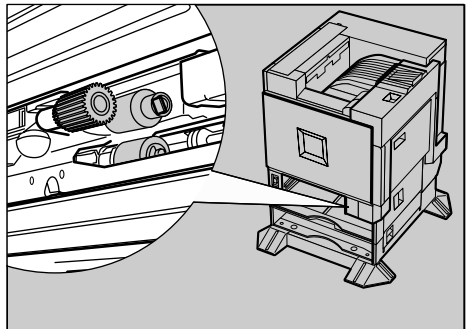

ZERH020E

Confirm the positions and names of each roller.

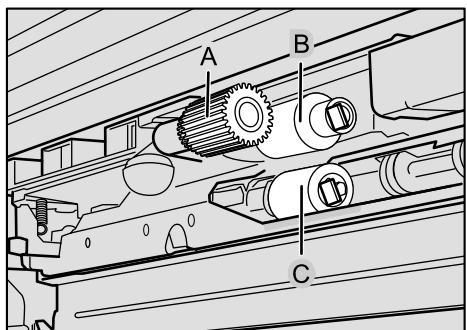

ZERH030E

1

- 5** While pushing the pin of paper feed roller A outwards (①), remove the paper feed roller (②).

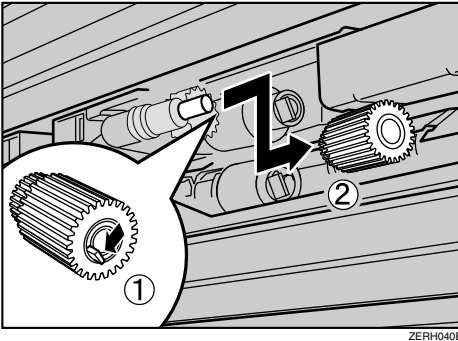

- 6** Remove the stopper from paper feed roller B (①), and remove the paper feed roller (②).

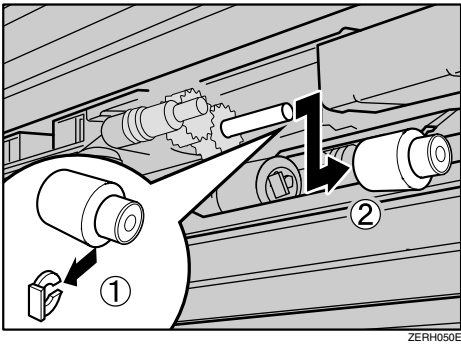

- 7** Remove the stopper from paper feed roller C (①), and remove the paper feed roller (②).

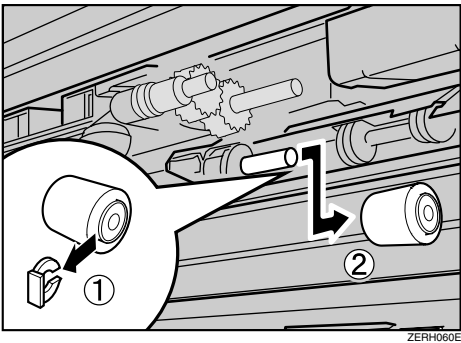

- 8** Hold the new paper feed roller C with its gear towards the shaft. Insert it into the rear shaft so that the roller gear is meshed with the shaft gear (①). Lock the roller with the stopper (②).

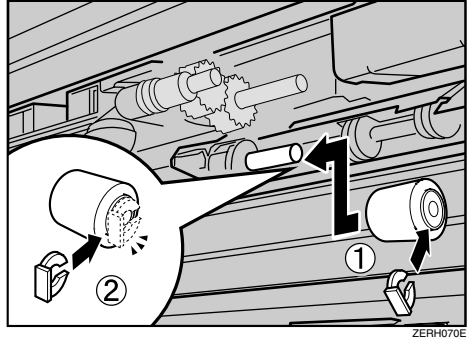

- 9** Hold the new paper feed roller B with its gear towards the shaft. Insert it into the rear shaft so that the roller gear is meshed with the shaft gear (①). Lock the roller with the stopper (②).

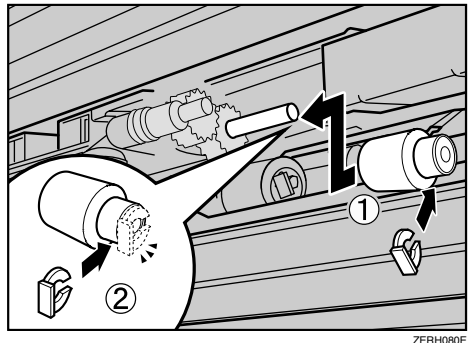

- 10** Hold the new paper feed roller A with its pin towards you (①). Insert the roller onto the front shaft until it clicks into place (②).

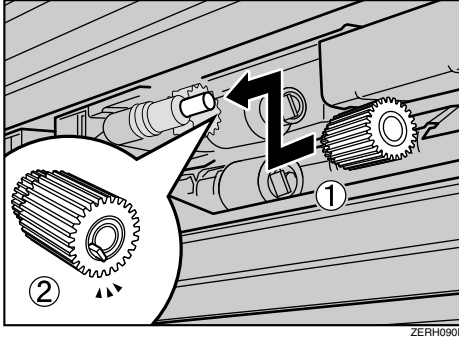

- 11** Slide all trays back into the printer slowly until they stop.

**Note**

- If you replaced the paper feed rollers of the optional 2000-sheet Large Capacity Tray, load the paper that you removed in step 2 in the tray.



# 2. Clearing and Adjusting the Machine

## Cautions to Take When Cleaning

**⚠ WARNING:**



- *Do not remove any covers or screws other than those specified in this manual. Some parts of the machine are at a high voltage and could give you an electric shock. Also, if the machine has laser systems, direct (or indirect) reflected eye contact with the laser beam may cause serious eye damage. When the machine needs to be checked, adjusted, or repaired, contact your service representative.*
- *Do not take apart or attempt any modifications to this machine. There is a risk of fire, electric shock, explosion or loss of sight. If the machine has laser systems, there is a risk of serious eye damage.*

Clean the printer periodically to maintain fine printing.

Dry wipe the exterior with a soft cloth. If dry wiping is not enough, wipe with a soft, wet cloth that is wrung out well. If you still cannot remove a stain or grime, use a neutral detergent, then wipe over with a well-wrung wet cloth, dry wipe, and let it dry.

**⚠ Important**

- To avoid deformation, discoloration, or cracking, do not use volatile chemicals, such as benzine and thinner, or spray insecticide on the printer.
- If there is dust or grime inside the printer, wipe with a clean, dry cloth.

# Cleaning the Registration Roller

**⚠ CAUTION:**

- The inside of the printer becomes very hot. Do not touch the parts with a label indicating the "hot surface", otherwise it could cause a burn.

Clean the roller when replacing the black Development Unit.

- 1** Turn off the power switch, and then unplug the power cable.
- 2** Open the right cover as shown in the illustration.



The registration roller is set as shown in the illustration.

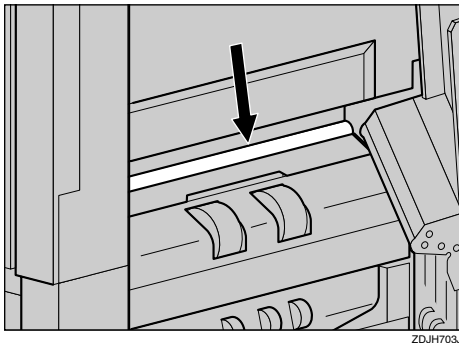

- 3** Wipe around the registration roller by turning with a soft damp cloth.

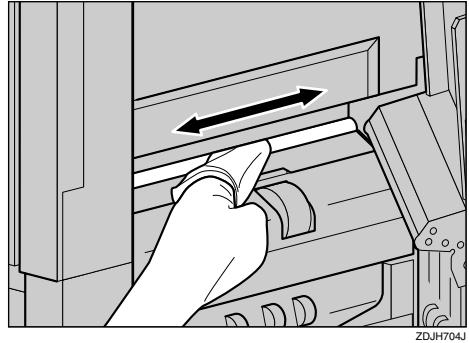

**⚠ Important**

- Do not use chemical cleaner or organic solvent such as thinner or benzene.

- 4** Close the right cover by pushing the area labeled "PUSH".

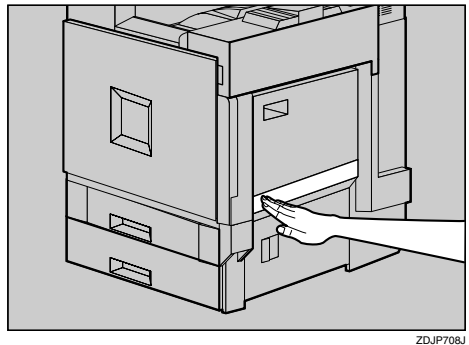

- 5** Plug in the power cable, and then turn on the power switch.



# Cleaning the Dustproof Glass

The dustproof glass may require cleaning if white lines appear on the print side of the document.

**1** Turn off the power switch, and then unplug the power cable.

**2** Open the front cover and remove the cleaning brush.

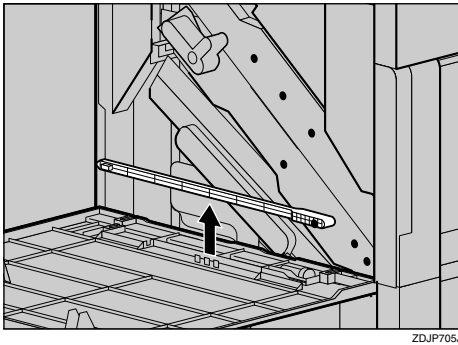

There are four holes for cleaning the dustproof glass.

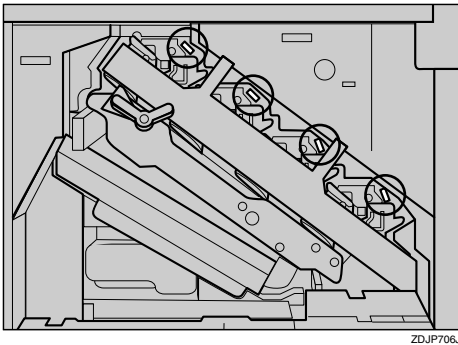

**3** Slide the cleaning brush in and out slowly 8 to 10 times to clean all four areas.

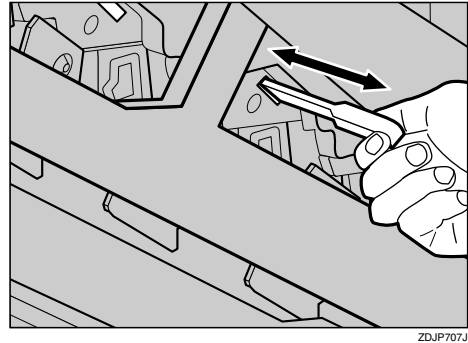

## ⚠ Important

- Do not insert the brush roughly, or the printer might be damaged.

**4** Return the cleaning brush to its original position.

**5** Plug in the power cable, and then turn on the power switch.

## Cleaning the Exposure Glass

If the exposure glass is dirty, you might not be able to make copies or scan as you want. If it is dirty, clean the exposure glass.

2

### ❖ Cleaning the machine

Wipe the machine with a soft, damp cloth. Then, wipe it with a dry cloth to remove the water.

### ⚠ Important

- ❑ Do not use chemical cleaner or organic solvent, such as thinner or benzene. If they get into the machine or melt plastic parts, a failure might occur.
- ❑ Do not clean parts other than those specified in this manual. Such parts should be cleaned by your service representative.

---

## Cleaning the Exposure Glass

---



GEWH050E

Clean 1 and 2.

# Cleaning the Cover

If the exposure glass cover or document feeder sheet is dirty, you might not be able to make copies or scan as you want. If they are dirty, clean them.

## ❖ Cleaning the machine

Wipe the machine with a soft, damp cloth. Then, wipe it with a dry cloth to remove the water.

## ⚠ Important

- Do not use chemical cleaner or organic solvent, such as thinner or benzene. If they get into the machine or melt plastic parts, a failure might occur.
- Do not clean parts other than those specified in this manual. Such parts should be cleaned by your service representative.

## When using the exposure glass cover

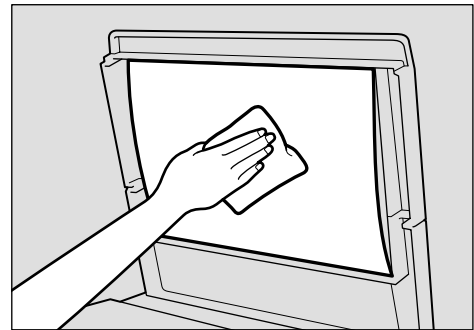

GEWH140E

2

## When using the document feeder

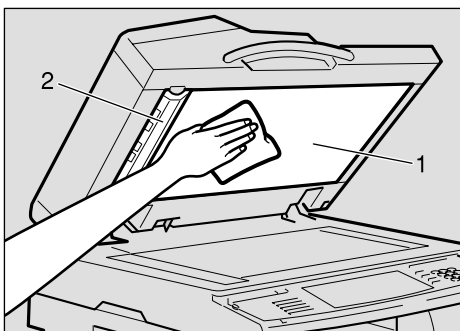

GEWH130E

Clean 1 and 2.

# Adjusting the Color Registration

When the printer is moved, the Fusing Unit is replaced, or after printing repeatedly for some time, registration shifting might occur. By performing color registration adjustment, you can maintain optimum print results.

**Note**

- Normally, do not perform manual color adjustment.

## Auto Adjustment

If the color documents show registration shifting, perform automatic color adjustment.

**1** Press the **[User Tools/Counter]** key.



"User Tools/Counter" appears on the panel display.

**2** Press **[Maintenance]**.

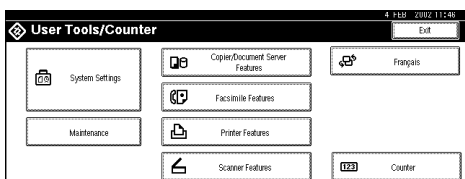

**3** Press **[Color Registration]**.

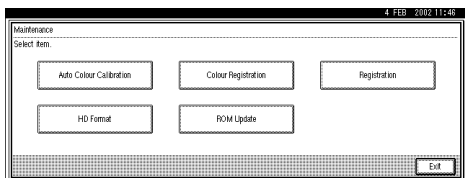

**4** Press **[Auto Adjustment]**.

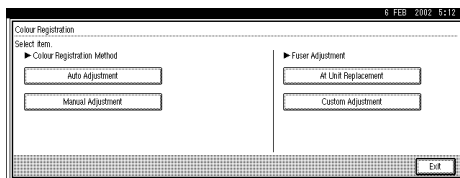

**5** Press **[OK]**.

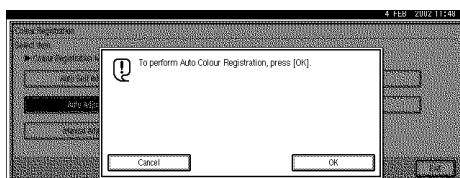

Auto adjustment will be started.

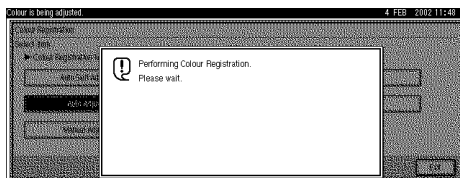

**Important**

- Do not turn off the power switch when "Color is Being adjusted." is shown on the panel display. This will cause a printer malfunction.

Automatic color adjustment takes about two minutes. When it is completed, the display returns to the color registration menu.

**6** When you have made all the settings, press the **[User Tools/Counter]** key.

The initial display is shown.

## Fuser Adjustment

### When replacing the fusing unit

#### Note

- If the toner has almost run out or Auto Adjustment has not finished, the Fuser Adjustment procedure cannot be carried out. Carry out the Fuser Adjustment procedure after replenishing the toner or after Auto Adjustment has finished.

**1** Load the A3 paper that comes with the new Fusing Unit in the Bypass Tray.

**2** Press the **[User Tools/Counter]** key.



"User Tools/Counter" appears on the panel display.

**3** Press **[Maintenance]**.

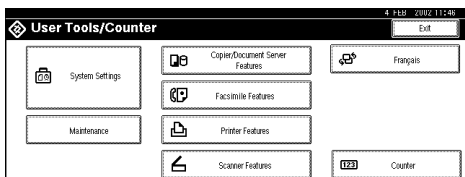

**4** Press **[Color Registration]**.

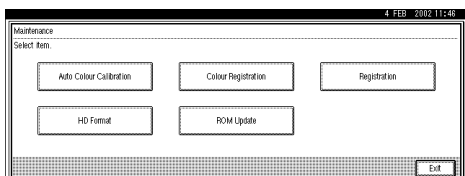

**5** Press **[At Unit Replacement]**.

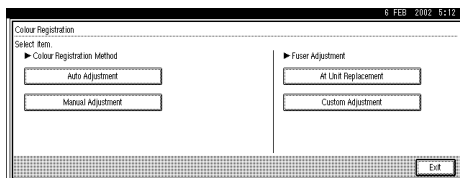

#### Important

- When the toner cartridge is almost empty or "Auto Adjustment" is not finished, the following message appears on the panel display and Fuser Adjustment is not available.

Confirm that the toner is not empty. If the toner is empty, replace the toner cartridge.

If the toner cartridge is not empty, perform "Auto Adjustment". See p.36 "Auto Adjustment".

**6** Press **[Print Fuser Adjust. Sheet]**.

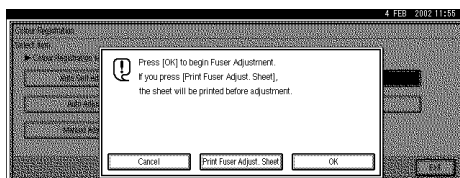

**7** Confirm that the A3 paper that comes with the Fusing Unit is in the Bypass Tray, and then press **[Start Printing]**.

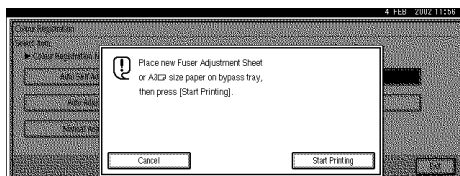

The printer prints 8 Test Sheets (A-H). For more information about Test Sheets, See p.42 "Test Sheet Samples".

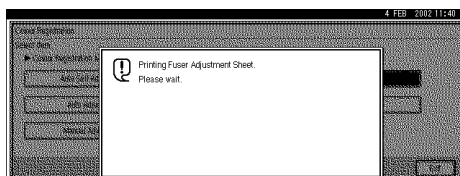

- 8 After printing the Fuser Adjustment Sheet, the Fuser Adjustment display appears. Adjust the print settings for boxes A - H on the Fuser Adjustment Sheet.

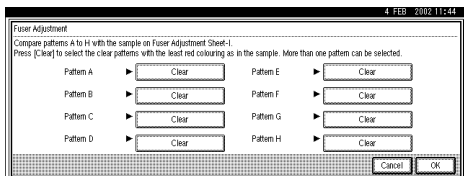

**Note**

- Check the printed Fuser Adjustment Sheet to adjust the print settings.

- 1 Compare box A of the pattern with the white square in the printed Fuser Adjustment Sheet. If the pattern is the same as the printed Fuser Adjustment Sheet, press [Clear]. If it is not, do not press [Clear].

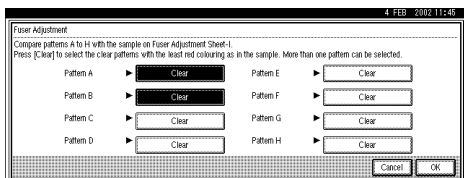

**Note**

- If you press [Clear] again, setting will be cancelled.

- 2 Repeat step 1 to make the settings for boxes B to H.

- 3 After making all the settings, press [OK].

**Note**

- If [Clear] is not pressed for one of the boxes, the following display appears. Press [Exit] and repeat the procedure from step 1.

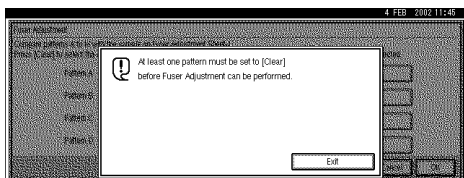

- 9 After making all the settings, press the [User Tools/Counter] key. The initial display is shown.

**When color shifting occurs**

Perform this procedure when color shifting occurs even after performing "Auto Adjustment".

- 1 Load A4 or larger paper in the Bypass Tray.

**Note**

- Be sure to select paper size in the "Paper Input" menu.

**Reference**

For details about paper size and the procedure for loading paper in the Bypass Tray, see "Loading Paper" in Maintenance Guide 2.

- 2 Press the [User Tools/Counter] key.



"User Tools/Counter" appears on the panel display.

- 3 Press [Maintenance].

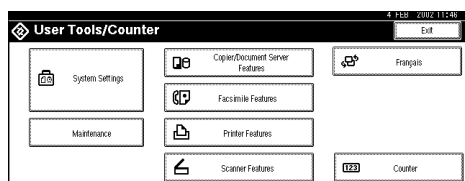

- 4 Press [Color Registration].

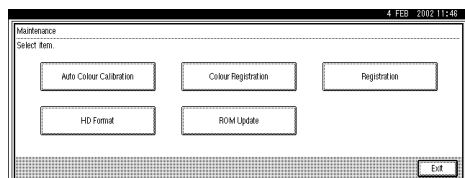

## 5 Press [Custom Adjustment].

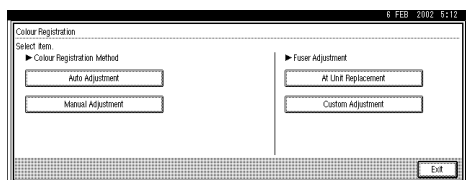

### Important

- When the toner cartridge is almost empty or "Auto Adjustment" is not finished, the following message appears on the panel display and Fuser Adjustment is not available.

Confirm that the toner is not empty. If the toner is empty, replace the toner cartridge.

If the toner cartridge is not empty, perform "Auto Adjustment". See p.36 "Auto Adjustment".

## 6 Select "Plain: 600dpi", "Plain: 1200dpi", or "Thick: 600dpi" as the value to adjust, and then press [OK].

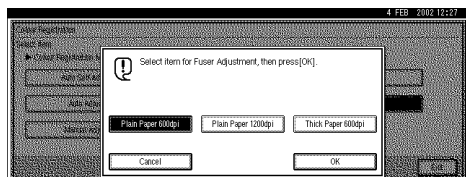

### Note

- The current resolution can be checked in the printer driver.
- To adjust the color registration for thick paper, select "Thick: 600dpi" regardless of the current resolution.

## 7 To print the Fuser Adjustment Sheet, make sure that A4 or larger paper is loaded in the Bypass Tray, and then press [Start Printing].

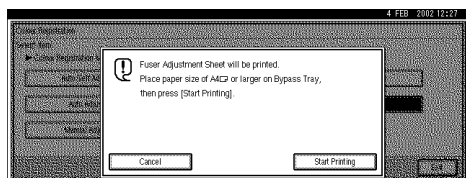

Fuser Adjustment Sheet II is printed. See p.42 "Test Sheet Samples".

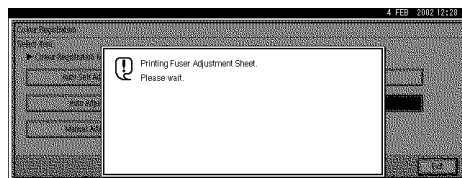

## 8 Compare box A of the printed pattern with the white square in the printed Fuser Adjustment Sheet. Specify which square in the box matches the printed Fuser Adjustment Sheet.

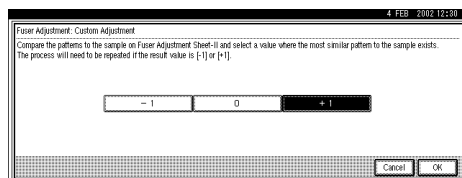

If you specify "0", setting is finished and the display that appeared in step 5 returns.

If you specify "-1" or "+1", the following display appears.

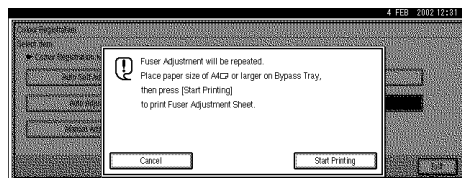

Press [Start Printing]. An adjusted Fuser Adjustment Sheet II is printed and the display that appeared in step 8 reappears. Keep adjusting until the printed pattern looks the same as the printed pattern, and then specify "0".

## 9 After making all the settings, press the [User Tools/Counter] key. The initial display is shown.

2

## Manual Adjustment

### Important

- Normally, do not carry out manual color adjustment.

**1** Press the **[User Tools/Counter]** key.

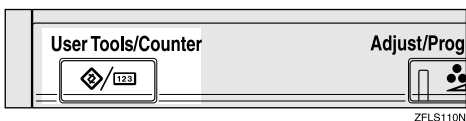

"User Tools/Counter" appears on the panel display.

**2** Press **[Maintenance]**.

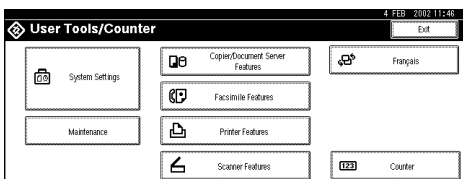

**3** Press **[Color Registration]**.

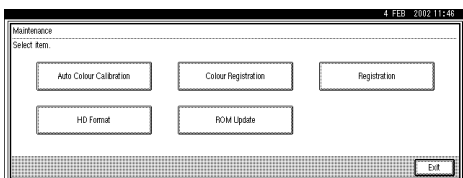

**4** Press **[Manual Adjustment]**.

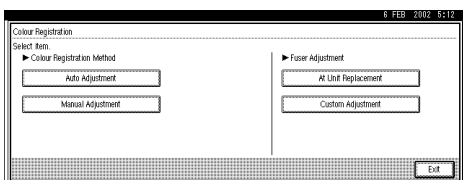

**5** Press **[Print Color Registration]** to print the Color Registration Sheet used for checking color registration.

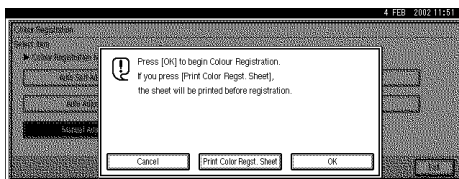

The Color Registration Sheet is printed. When printing finishes, the "Color Registration" display appears.

### Reference

See p.42 "Test Sheet Samples".

### Note

- To print the Color Registration Sheet, load A4 paper in the standard tray.

**6** Set the correct values for boxes A through L on the printed Color Registration Sheet.

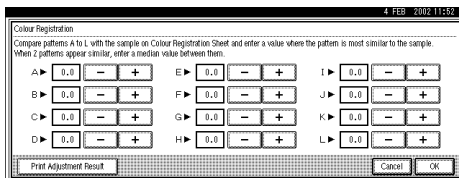

### Note

- Use the printed Color Registration Sheet as a standard for setting the correct values.



- 1 Compare squares -7 to +7 in box A of the printed pattern with the white square in the printed Color Registration Sheet. Use [+] or [-] to enter the value (-7 to +7) of the square in box A of the printed pattern that comes closest to matching the printed Color Registration Sheet.

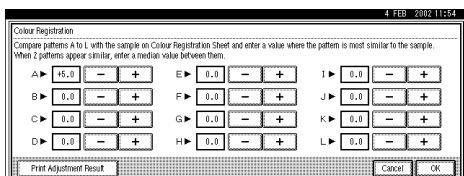

#### Note

- Pressing [+] or [-] increases or decreases the value by 0.5 step.

If the two whitest squares are equally white, enter their intermediate value. For example, if the "+1" and "+2" squares are the whitest, enter "+1.5".

The color registration adjustment range for each color is -7 to +7.

There is an area on the Color Registration Sheet where you can write down the values for boxes A through L.

- 2 Repeat step 1 to make the settings for boxes B to L.
- 3 After making all the settings, press [Print Adjustment Result].  
The adjusted sheet is printed.

- 4 Make sure that square "0" is the whitest within boxes A through L on the printed Color Registration Sheet.

#### Note

- If a square other than "0" is the whitest, repeat the procedure from step 4.

- 7 After making all the settings, press the [User Tools/Counter] key.  
The initial display is shown.

# Test Sheet Samples

Following images are samples of the test sheet.

## ❖ ColorRegistSheet

2

Colour Regist Sheet

The test sheet consists of 12 columns (A-L) and 15 rows of patterns. Each pattern is labeled with a number from -7 to +7. The patterns consist of horizontal lines of varying thickness and spacing. A legend shows a 'Sample' of a single line and a 'Sample' of a group of lines. Below the patterns are two rows of boxes labeled A through L.

A	B	C	D	E	F
G	H	I	J	K	L

❖ Fuser Adjust Sheet I



Fuser Adjust Sheet I



Sample



Pattern:A

## ❖ Fuser AdjustSheet II

2

Fuser Adjust Sheet II

 Sample



# Adjusting the Color Calibration

The color calibration can change slightly as a result of a number of factors. For instance, the color may change after many prints have been made or after a new toner cartridge has been installed. If this happens, the machine can be made to produce the appropriate color by adjusting the color calibration. Normally, however, you do not need to do this.

## Note

- ❑ Adjusting a printer's color calibration will affect the output of all users who use that printer.
- ❑ You cannot print the Test Pattern Sheet using paper loaded in the Bypass Tray.

## Auto Color Calibration

In color calibration, this machine automatically adjusts the printed highlights and mid-tones.

## Note

- ❑ The machine will not carry out Auto Color Calibration if the toner has almost run out.
- ❑ Use the same type of paper for each test pattern print. Inaccurate calibration can occur if different types of paper are used.

- 1** Press the **[User Tools/Counter]** key.



"User Tools/Counter" appears on the panel display.

- 2** Press **[Maintenance]**.

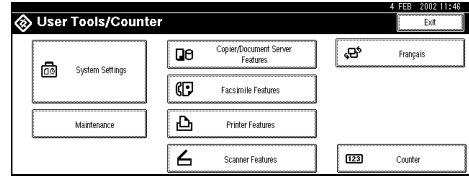

- 3** Press **[Auto Color Calibration]**.

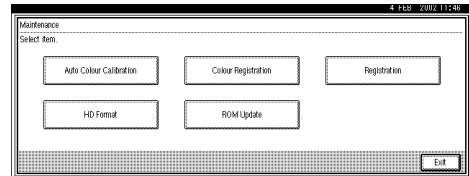

- 4** When adjusting the color calibration in copy mode, press **[Start]** to the right of **[Copier Function]**. When adjusting the color calibration in printer mode, press **[Start]** to the right of **[Printer Function]**.

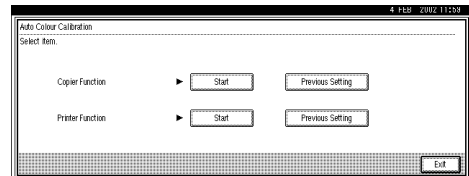

- 5** Print the Test Pattern.

If you have adjusted the color calibration in copy mode, go to step **1**.

If you have adjusted the color calibration in printer mode, the resolution selection display appears. In this case, go to step **2**.

2

- 1 If you have adjusted the color calibration in copy mode, the following display appears. Press [Start Printing].

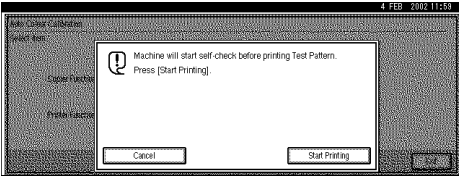

- 2 If you have adjusted the color calibration in printer mode, the following display appears. Select [600 x 600 dpi], [1200 x 600 dpi], or [1200 x 1200 dpi] as the resolution for color calibration, and then press [Start Printing].

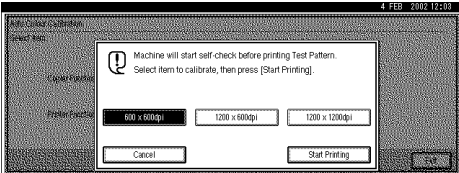

The test pattern will be printed.

**Note**

- Immediately after selecting [Start Printing] from this menu, a self-check starts. Wait a few minutes for the test pattern to be printed.

**Important**

- If the toner has almost run out, the message "Test Pattern could not be printed." appears on the control panel and the machine does not carry out Auto Color Calibration. Make sure there is sufficient toner for Auto Color Calibration. If there is not, replace the cartridge. See p.4 "Replacing the Toner Cartridge".

- 6 Place the printed arrow of the test pattern sheet at the left corner of the exposure glass with the printed side down.

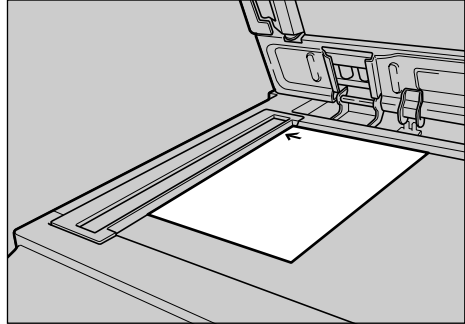

ZFOC030J

- 7 Press [Start Scanning].

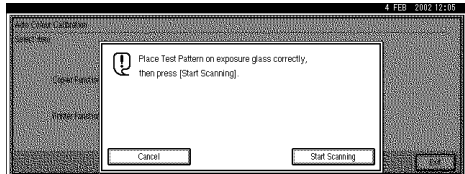

Adjustment of the color calibration starts.

**Note**

- If the sheet is not loaded properly, the following message appears.

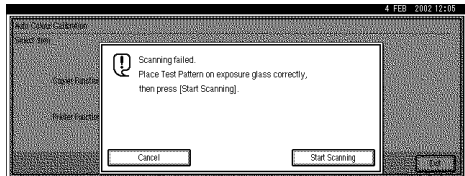

- 8 When all the settings have been made, press the [User Tools/Counter] key.

The initial display is shown.

---

## Verifying the Test Pattern Sheet

---

This is the test pattern sheet that is printed out when carrying out Auto Color Calibration. Place the printed arrow of the sheet at the left corner of the exposure glass and scan the sheet to automatically start color calibration.

### ❖ Test Pattern Sheet for Copy Mode

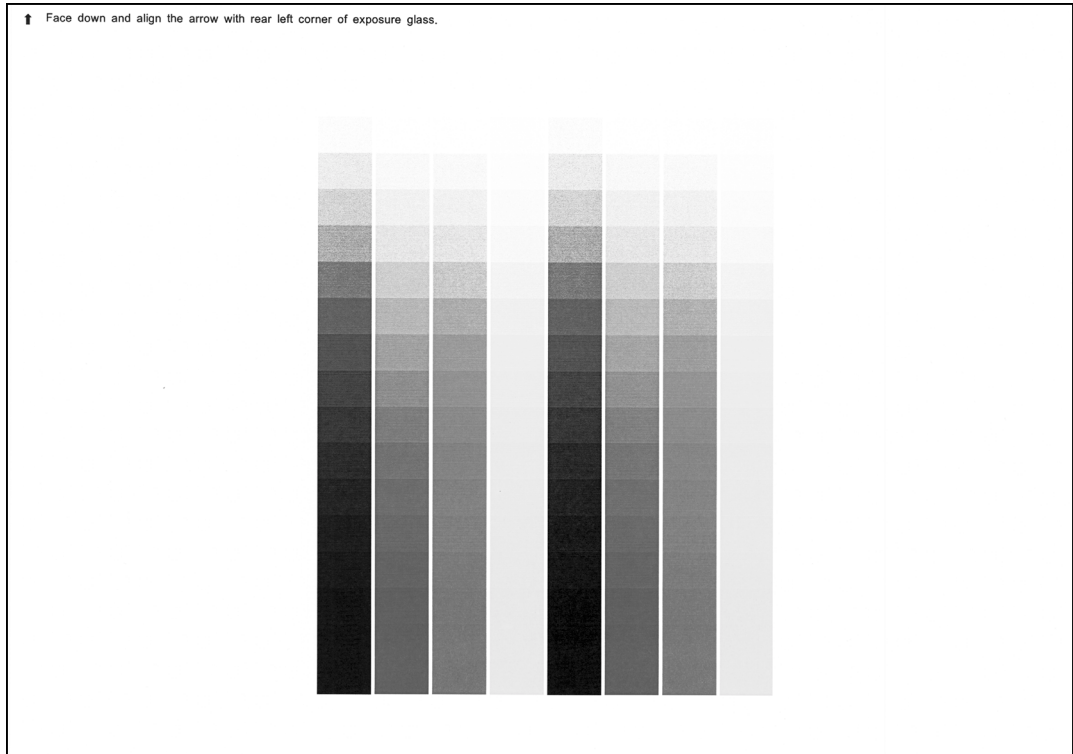

## ❖ Test Pattern Sheet for Printer Mode

Face down and align the arrow of this sheet with rear left corner of exposure glass.

Auto Color Calibration Test Pattern (600x600dpi)

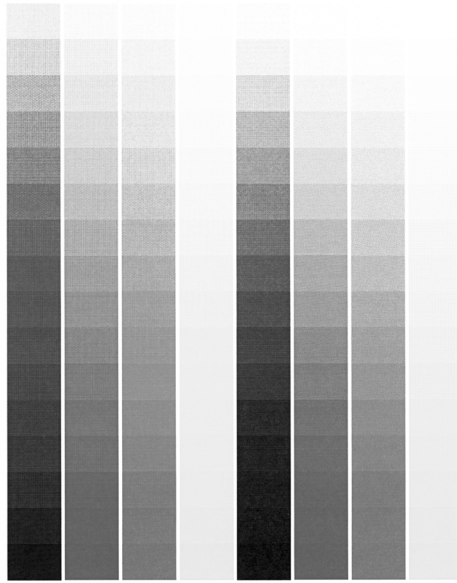

2



## Restoring Previous Color Calibration Settings

You can restore previous color calibration settings.

- 1 Press the **[User Tools/Counter]** key.

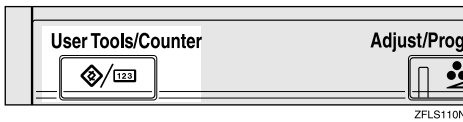

"User Tools/Counter" appears on the panel display.

- 2 Press **[Maintenance]**.

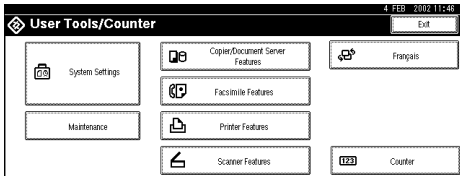

- 3 Press **[Auto Color Calibration]**.

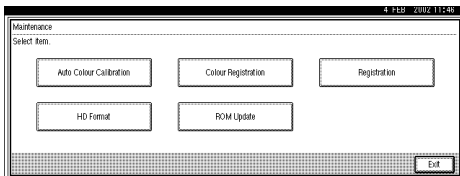

- 4 To restore previous color calibration settings in copy mode, press **[Previous Setting]** to the right of **[Copier Function]**. To restore previous color calibration settings in printer mode, press **[Previous Setting]** to the right of **[Printer Function]**.

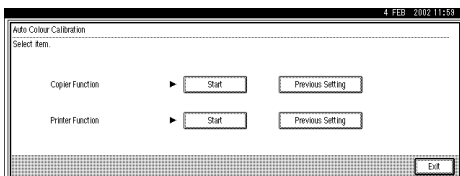

If you have adjusted the color calibration in copy mode, go to step **1**.

If you have adjusted the color calibration in printer mode, the resolution selection display appears. In this case, go to step **2**.

- 1 When restoring previous color calibration settings in copy mode, the display shown below appears. Press **[Previous Setting]**.

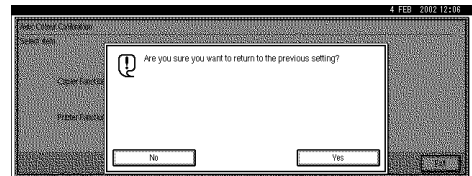

- 2 When restoring previous color calibration settings in printer mode, the display shown below appears. Select **[600 x 600 dpi]**, **[1200 x 600 dpi]**, or **[1200 x 1200 dpi]** as the resolution for color calibration, and then press **[Previous Setting]**.

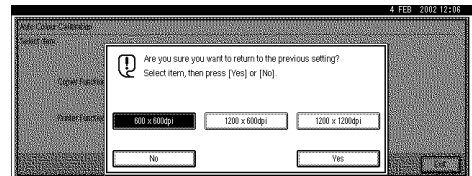

- 5 When all the settings have been made, press the **[User Tools/Counter]** key.

The initial display is shown.

# Adjusting the Registration of the Trays

You can adjust the registration of each tray. The vertical adjustment is used for all trays. Normally, you need not update the registration. But when the optional Paper Feed Unit or the Duplex Unit is installed, updating the registration is useful in some cases. The following procedure describes how to adjust Tray 3. You can use the same procedure to adjust the other tray as well.

2

**1** Press the **[User Tools/Counter]** key.

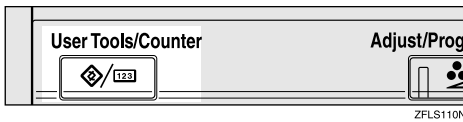

"User Tools/Counter" appears on the panel display.

**2** Press **[Maintenance]**.

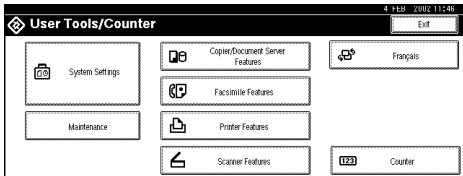

**3** Press **[Registration]**.

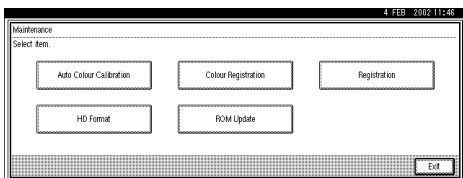

**4** Print the test sheet to preview the registration.

**1** Press **[Print Test Sheet]**.

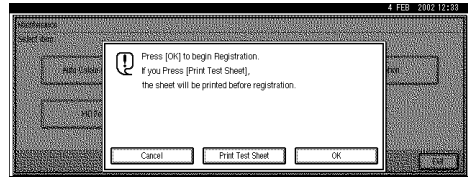

**2** Press either **[Tray3]** or **[Back of 2-Sided]** to select the tray you want to adjust the registration for.

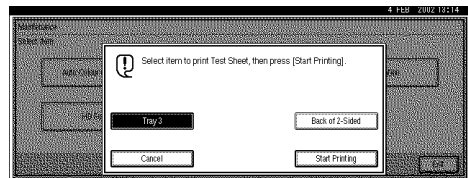

**3** Press **[Start Printing]**.

**5** Select the item to adjust.

**1** Press **[OK]**.

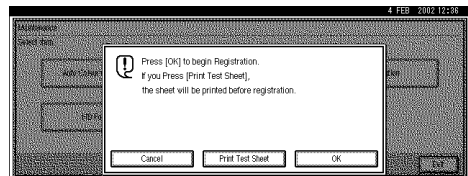

**2** Press either **[Tray3]** or **[Back of 2-Sided]** to select the tray you want to adjust the registration for.

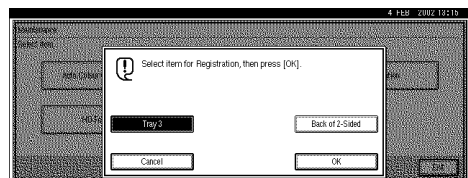

**3** Press **[OK]**.

- 6** Check the position of the image on the test sheet, and then adjust the registration.

**Note**

- When checking the registration, use the feeding direction as a reference. Since the feeding direction is the same as the delivery direction, be sure to check the feeding direction.

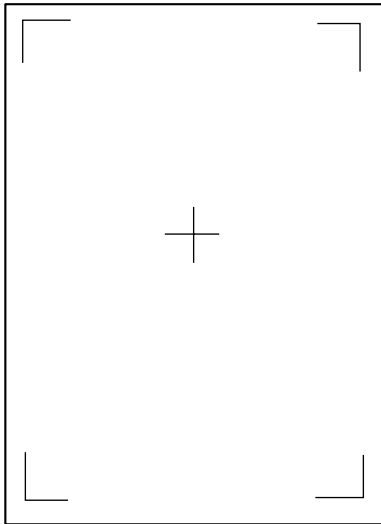

The following procedure makes the margins on the Print Test Sheet equal.

- 1** Press [↑] or [↓] to increase or decrease the registration value (mm).

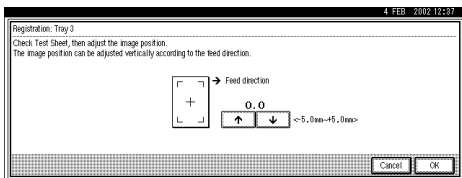

**Note**

- Increase the value to shift the print area in the positive direction, decrease it to shift the print area in the negative direction.

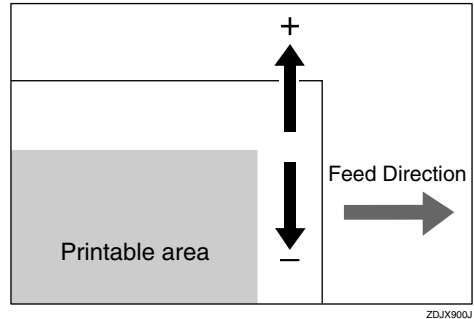

Pressing [↑] or [↓] increases or decreases the value by 1.0 mm step.

- 2** Press [OK].

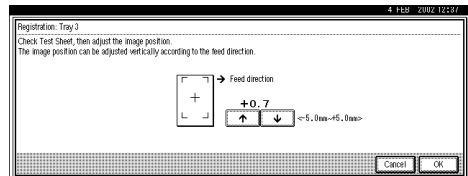

The display returns to the one that appeared in step 4.

- 7** Print the Print Test Sheet in the same way as in step 4, and then check whether the registration is correct or not.

**Note**

- If the registration is still not correct, repeat the procedure from step 5.

- 8** If the registration is correct, press [Cancel].

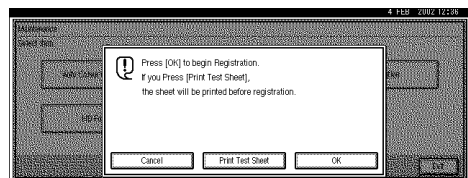

- 9** After making all the settings, press the [User Tools/Counter] key.

The initial display is shown.



# 3. Appendix

## Removing Misfed Paper in the Duplex Feed Unit

You can remove misfed paper from the Duplex Feed Unit following the procedure below.

### Note

- ❑ When a paper misfeed occurs in the Duplex Feed Unit, the printer usually sends the misfed paper to the right cover and there is no need to execute the following procedure. See "When "Remove Misfeed A:Internal Path" Appears" in Maintenance Guide 2.

### Important

- ❑ Be sure to remove misfed paper following the procedure below only when "Paper in duplex unit. Open cover and remove paper." appears on the panel display.

**1** Turn off the power switch, and then unplug the power cable.

**2** Open the front cover slowly by pulling down from the two areas on the left and right.

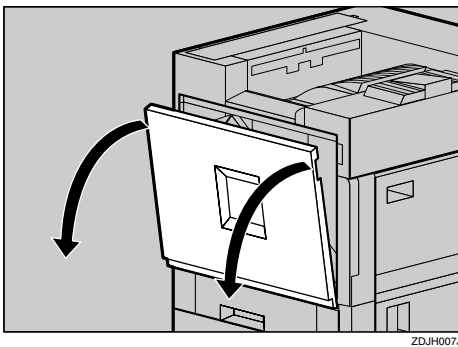

**3** Take out the green screwdriver.

Use this screwdriver to attach and detach all screws.

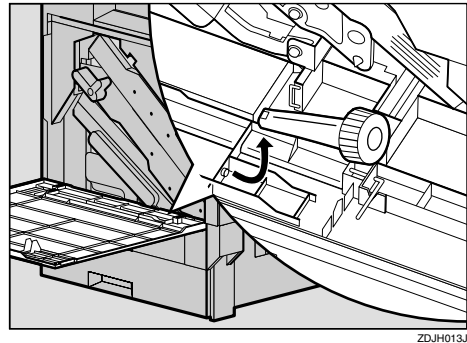

**4** Remove the screw that fastens the Duplex Feed Unit using the provided screwdriver.

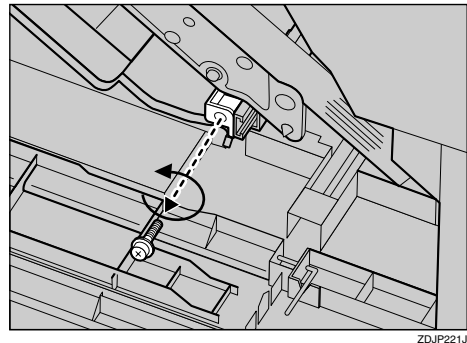

You will use this screw to refasten the Duplex Feed Unit later.

- 5** Pinch the upper left area of the Duplex Feed Unit, and pull it out slowly halfway.

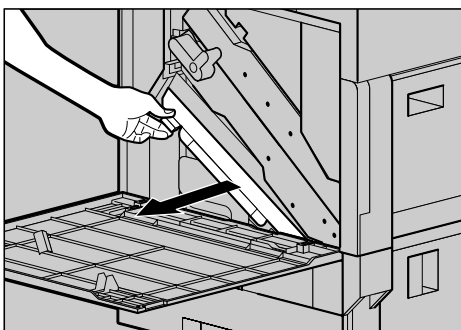

ZDJP213J

- 6** Holding the Duplex Feed Unit firmly with both hands, pull it straight out.

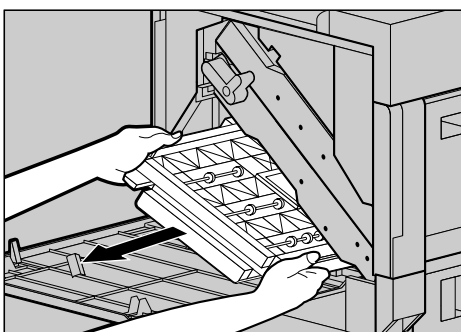

ZDJP214J

- 7** Place the Duplex Feed Unit on the floor slowly. Open it slowly, and remove the misfed paper.

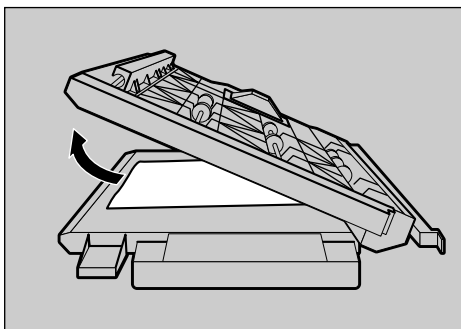

ZDJP215J

- 8** Close the Duplex Feed Unit.

- 9** Holding the Duplex Feed Unit with both hands, insert it along the rails slowly until it stops.

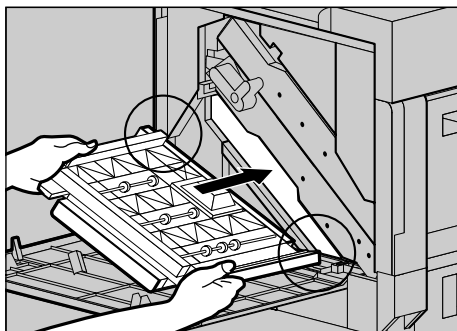

ZDJP056J

The top and bottom rails are located in the position shown in the illustration.

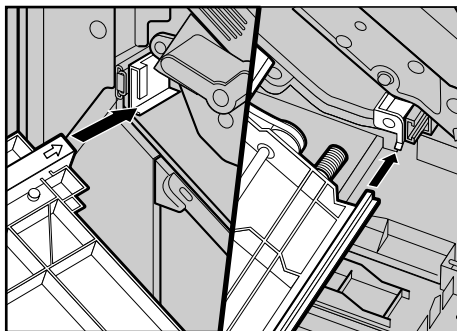

ZDJP133J

There are two arrows located on the left and right sides of the Duplex Feed Unit.

### Important

- Do not open the Duplex Feed Unit by force. It might damage the unit.

- 10** Refasten the Duplex Feed Unit using the provided screwdriver. Use the screw that was removed in step **4**.

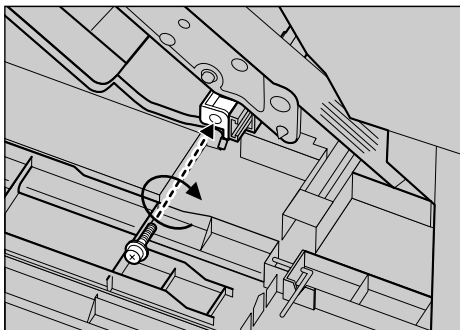

ZDJP057J

 **Note**

- Be sure to return the provided screwdriver to its original position on the inside of the front cover.

- 11** Close the front cover slowly by pushing the two areas on the left and right.

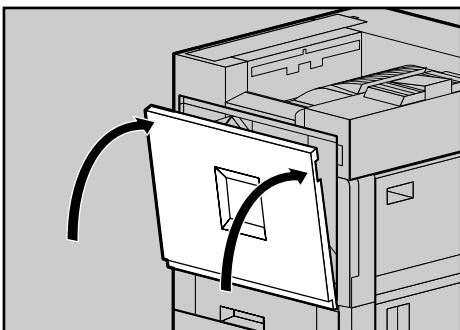

ZDJH041J

- 12** Plug in the power cable, and then turn on the power switch.

# Consumables

## ⚠ CAUTION:

- *Our products are engineered to meet the highest standards of quality and functionality. When purchasing expendable supplies, we recommend using only those specified by an authorized dealer.*

## ❖ Toner cartridge

Toner cartridge	Average printable number of pages per cartridge <sup>*1</sup>
Cyan	10,000 pages
Magenta	10,000 pages
Yellow	10,000 pages
Black	20,000 pages

<sup>\*1</sup> A4 5% test chart, 5 pages/job

## 📝 Note

- The actual number of printed pages you get from a particular toner cartridge depends on the type and size of paper you are using, the contents of your print images, and the printing environment conditions. All this means that a toner cartridge might require replacement sooner than the normal life described above.
- Toner cartridges that come with the printer are for setup purposes, and will not provide the number of pages described above. The average number of printable pages that can be expected from the toner cartridges included in the printer are as follows:
  - Black toner cartridge : about 10,000 pages
  - Cyan, magenta and yellow toner cartridges : about 5,000 pages for each cartridge.

## ❖ Staple Cartridge

Cartridge type	Number of shots
Staple cartridge	5000 shots × 1 with cartridge
Staple Refill cartridge	Refill 5000 shots × 3



## ❖ Other consumables

### Note

- ❑ The actual life of consumables depends on the type and size of paper you are using, the contents of your print images, and the printing environment conditions. All this means that consumables might require replacement sooner than the life indicated. Furthermore, the life of color consumables may considerably shorten as mixed printing of black & white pages and color pages frequently occurs.

Name	Consumables	Average printable number of pages <sup>*1</sup>
Printer Maintenance Kit Type 3800A	Color Photoconductor Unit × 3	50,000 pages <sup>*2</sup>
Printer Maintenance Kit Type 3800B	Color Development Unit × 3	100,000 pages <sup>*2</sup>
Printer Maintenance Kit Type 3800C	Fusing Unit × 1	100,000 pages <sup>*2</sup>
Printer Maintenance Kit Type 3800D	Black Development Unit × 1	100,000 pages <sup>*2</sup>
Printer Maintenance Kit Type 3800E	Used Toner Bottle × 1	50,000 pages
Printer Maintenance Kit Type 3800F	Black Photoconductor Unit × 1	50,000 pages <sup>*2</sup>
Printer Maintenance Kit Type 3800G	Fusing Oil Unit × 1	20,000 pages <sup>*2</sup>
Printer Maintenance Kit Type 3800H	Paper Feed Rollers × 1	150,000 pages

<sup>\*1</sup> A4 5% test chart, 5 pages/job

<sup>\*2</sup> When printing each page as a single job, the unit needs extra idling, thus reducing the unit's print life by half.

# INDEX

## A

---

- Adjusting the Color Calibration, 45
- Adjusting the Color Registration, 36
  - Auto Adjustment*, 36
  - Fuser Adjustment*, 37
  - Manual Adjustment*, 40
- Adjusting the Registration of the Trays, 50
- Appendix, 53

## C

---

- Caution, ii
- Cleaning the Cover, 35
- Cleaning the Dustproof Glass, 33
- Cleaning the Registration Roller, 32
- Clearing and Adjusting the Machine, 31
- Consumables, 56

## D

---

- Detaching the PT460 (Multi-bin), 2
- Detaching the SR770 (2 Tray Finisher), 1
- Duplex Reversal Unit
  - Opening and Closing*, 3

## E

---

- Exposure glass
  - Cleaning*, 34

## M

---

- Maintenance, 34

## R

---

- Removing Misfed Paper into the Duplex Feed Unit, 53
- Replacing Consumables and Maintenance Kit, 1
- Replacing the Development Unit, 15
- Replacing the Dustproof Filter, 23
- Replacing the Fusing Oil Unit, 7
- Replacing the Fusing Unit, 19
- Replacing the Photoconductor Unit, 11
- Replacing the Toner Cartridge, 4
- Replacing the Used Toner Bottle, 25

## S

---

- Safety Information, ii

## T

---

- Test Sheet Samples
  - Color Regist Sheet*, 42
  - Fuser Adjust Sheet I*, 42
  - Fuser Adjust Sheet II*, 42
- Toner Cartridge, 56

## W

---

- Warning, ii

## Note to users in the United States of America

### Notice:

This equipment has been tested and found to comply with the limits for a Class B digital device, pursuant to Part 15 of the FCC Rules. These limits are designed to provide reasonable protection against harmful interference in a residential installation. This equipment generates, uses and can radiate radio frequency energy and, if not installed and used in accordance with the instructions, may cause harmful interference to radio communications.

However, there is no guarantee that interference will not occur in a particular installation. If this equipment does cause harmful interference to radio or television reception, which can be determined by turning the equipment off and on, the user is encouraged to try to correct the interference by one more of the following measures:

**Reorient or relocate the receiving antenna.**

**Increase the separation between the equipment and receiver.**

**Connect the equipment into an outlet on a circuit different from that to which the receiver is connected.**

**Consult the dealer or an experienced radio/TV technician for help.**

### Warning

Changes or modifications not expressly approved by the party responsible for compliance could void the user's authority to operate the equipment.

### Caution (in case of 100BaseTX environment):

Properly shielded and grounded cables (STP) and connectors must be used for connections to host computer (and/or peripheral) in order to meet FCC emission limits.

### Declaration of Conformity

Product Name: Laser Printer

Model Number: AP3800C/AP828/SLP38c/DSc38

Responsible party: Ricoh Corporation

Address: 5 Dedrick Place, West Caldwell, NJ 07006

Telephone number: 973-882-2000

This device complies with part 15 of FCC Rules.

Operation is subject to the following two conditions:

1. This device may not cause harmful interference, and
2. this device must accept any interference received, including interference that may cause undesired operation.

**Properly shielded cables must be used for connections to host computer (and/or peripheral) in order to meet FCC emission limits.**

**Network interface cable with ferrite core must be used for RF interference suppression.**

## Note to users in Canada

### Note:

This Class B digital apparatus complies with Canadian ICES-003.

## Remarque concernant les utilisateurs au Canada

### Avertissement:

Cet appareil numérique de la classe B est conforme à la norme NMB-003 du Canada.

In accordance with IEC 60417, this machine uses the following symbols for the main power switch:

**I** means POWER ON.

**O** means POWER OFF.

**⏻** means STAND-BY

